

Thank you for purchasing the UT-109/UT-110 SCRAMBLER UNIT. The UT-109 and UT-110 are designed for Icom F series VHF/UHF FM transceivers.

Please read these instructions thoroughly before installing and operating the UT-109/UT-110.

### IC-F300/F400/S SERIES PRECAUTIONS

- Some transceiver versions will not be able to have scrambler units installed because of CPU revision and other factors. Please confirm that the transceivers' serial number is over 50000.
- UT-109 and UT-110 scrambler units require some PC board modifications. (See below.)
- There are 2 versions (#01: Low AF level type for IC-F3/F4/S series and #02: High AF level type for the

others) for each scrambler unit. Do not install the wrong version, as they are not compatible.

- IC-F300/F400/S series require the #02 type scrambler unit.
- The UT-110 may function as the UT-109 through cloning software.
- Compatible cloning software: CS-F300S, CS-F300.

### PC BOARD MODIFICATION

The scrambler unit may be installed between the mic amplifier circuit and AF circuit. Cut or desolder the junction points (or take off jumper chip for IC-F3/F4/S series).

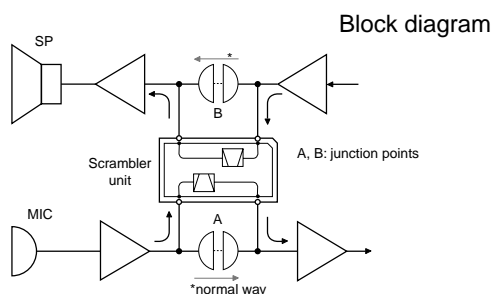

#### ■ IC-F300/F400/S series

- ① Turn power OFF, then disconnect the DC power cable.
- ② Unscrew the 4 screws, then remove the bottom cover.
- ③ Cut or desolder the print pattern on the PC board at the TX mic circuit (A) and RX AF circuit (B).
- ④ Install the unit as shown in the instruction manual.
- ⑤ Replace the bottom cover and screws, then the DC power cable.

#### NOTE:

Modification points are marked A or B on the circuit board. (see corresponding figures)

A : TX modulation circuit.

B : RX AF circuit.

\* Desolder, remove a jumper chip or cut the pattern

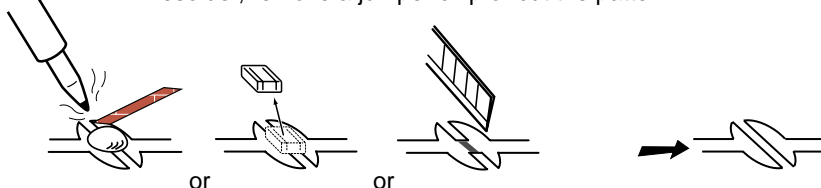

### CLONING

- Program the scrambler function ON/OFF and scrambler codes on the [Memory CH] screen, scrambler type\*, group codes\*, synchronous capture mode\* and tone start timing\* on the [Common] screen with cloning software when installing this unit. (\*UT-110 only)

- Assign the scrambler function to a programmable key as [SCRM] on [Key & Display Assign] screen, if required.

- Operation with the [SCRM] key:

- Push and hold to turn the voice scrambler function ON.
- Push to turn the voice scrambler function OFF.

### NOTE FOR REMOVAL

Be sure to resolder above disconnected points, otherwise no TX modulation or AF output is available when you remove the scrambler units.

## IC-F300/F400/S SERIES MODIFICATION POINTS

■ Model: IC-F300/S series

Main board A and B.

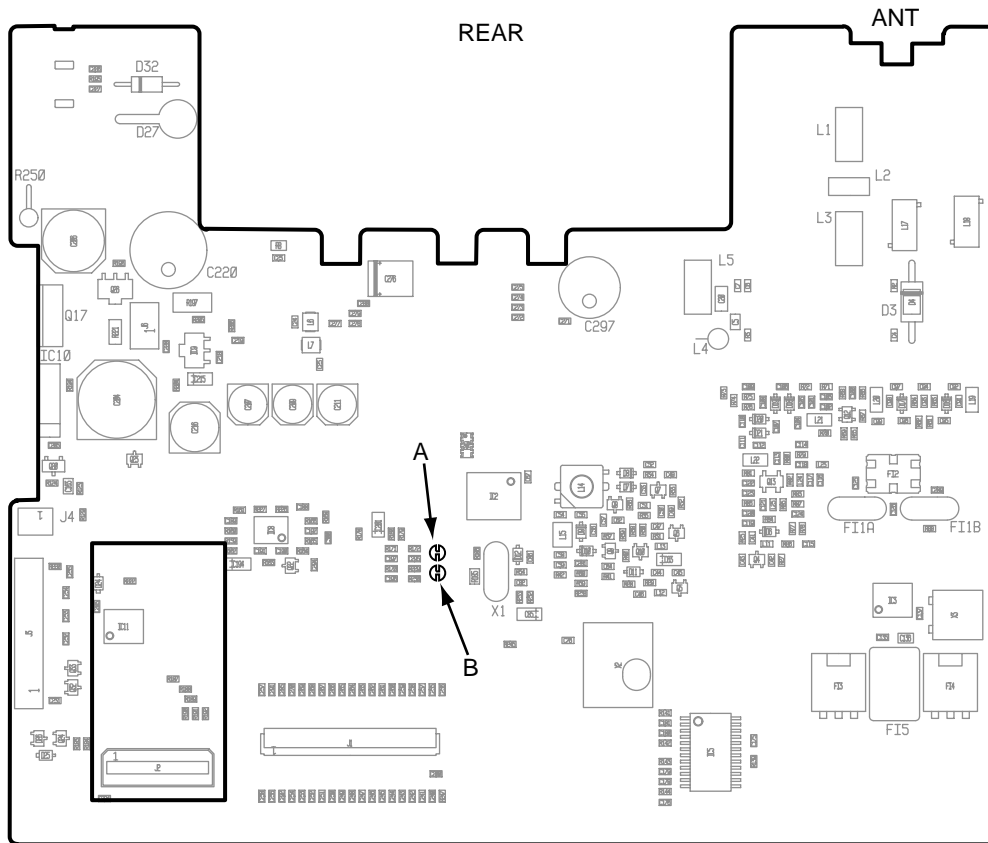

■ Model: IC-F400/S series

Main board A and B.

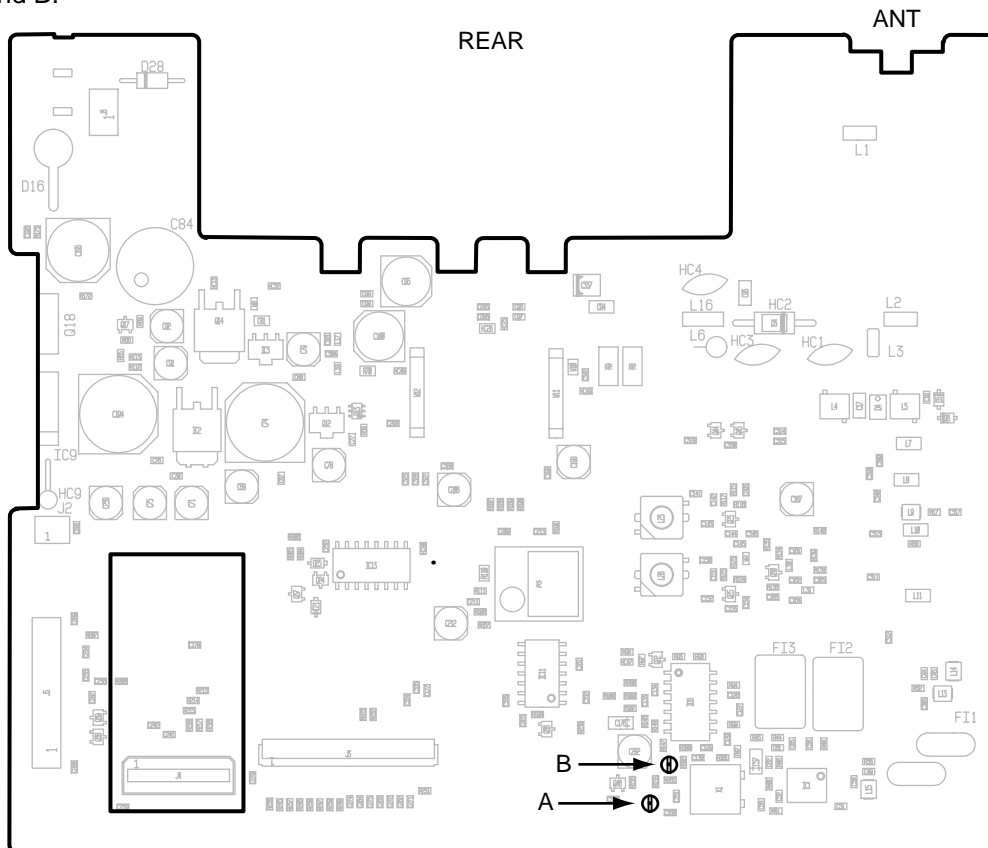

## APPENDIX -1; IC-F3/F4/S SERIES PRECAUTIONS

- Some transceiver versions will not be able to have scrambler units installed because of CPU revision and other factors. Please confirm that the transceivers' serial number is over 50000.
- UT-109 and UT-110 scrambler units require some PC board modifications. (See below.)
- IC-F3/F4/S series require a #01: Low level type scrambler unit. Do not install the wrong version, as

they are not compatible.

- The UT-110 may function as the UT-109 through cloning software.
- Compatible cloning software: CS-F3.

## PC BOARD MODIFICATION

### ■ IC-F3/F4/S series

There are 2 types of PC boards exist. Be sure to confirm the board number in advance.

#### • IC-F3/IC-F3S

➔ B4929E requires LCD side and CPU side modifications.

➔ B4929F\*1 requires CPU side only.

#### • IC-F4/IC-F4S

➔ B4923G LCD side and CPU side modifications.

➔ B4923H\*1 requires CPU side only.

- ① Take out the knob and unscrew the antenna connector screw.
- ② Unscrew the 2 screws, then remove the front panel.
- ③ Remove the shield cover if necessary.
- ④ Remove the jumper chip (DET)\*2 or (AF)\*2 on the LCD side of the PC board.
- ⑤ Replace the shield cover to the original position.
- ⑥ Remove the jumper chip resistor(s) on the CPU side of the PC board. (see right figures)
- ⑦ Install the unit as shown in the instruction manual.
- ⑧ Replace the front panel and screws.

### NOTE:

\*1 B4929F and B4923H's modification points may access through the service window without take



apart.

\*2 Modification points are marked DET or AF on the main board. (see below figures)

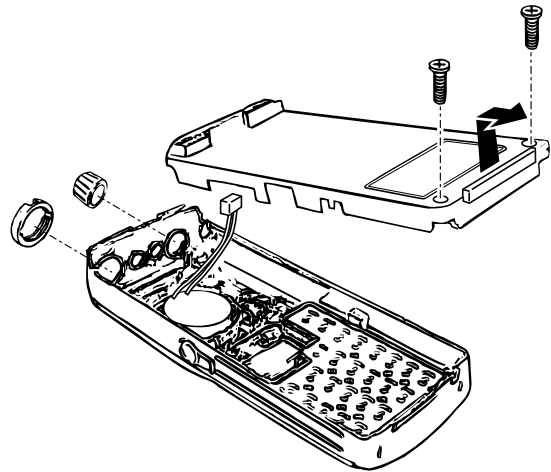

## CLONING

- Program the scrambler function ON/OFF and scrambler codes on the [Memory CH] screen, scrambler type\*, group codes\*, synchronous capture mode\* and tone start timing\* on the [Common] screen with cloning software when installing this unit. (\*UT-110 only)
- Assign the scrambler function to a programmable key as [SCRM] on [Key & Display Assign] screen, if required.
- Operation with the [SCRM] key:

- Push and hold to turn the voice scrambler function ON.
- Push to turn the voice scrambler function OFF.

## NOTE FOR REMOVAL

Be sure to resolder above disconnected points, otherwise no TX modulation or AF output is available when you remove the scrambler units.

## IC-F3/F4 SERIES MODIFICATION POINTS

**Model: IC-F3/IC-F3S**

PC board number B4929E; Remove the LCD side jumper chip and the CPU side jumper chip ①.  
 B4929F; Remove the CPU side jumper chips ① and ②.

• LCD side: B4929E only.

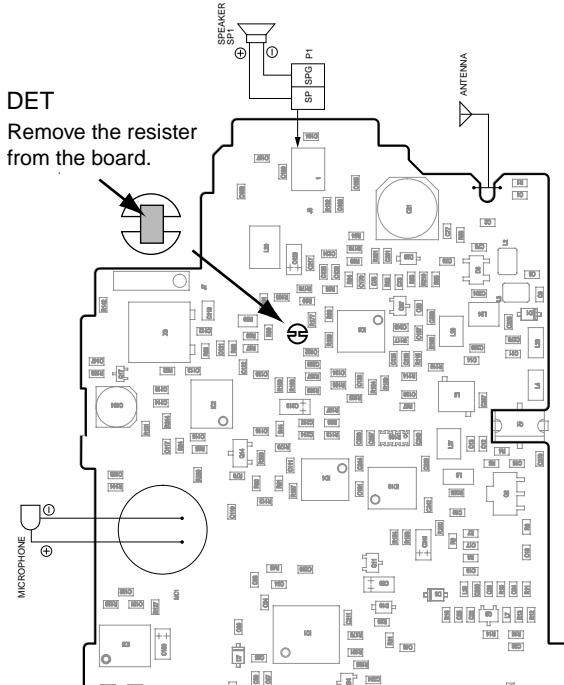

• CPU side

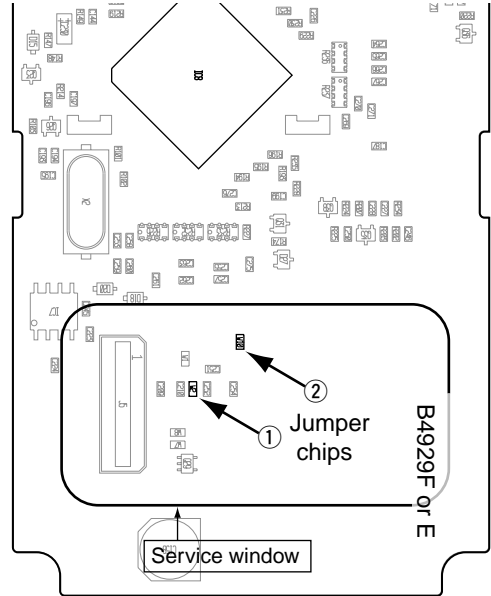

**Model: IC-F4/IC-F4S**

PC board number B4923G; Remove the LCD side jumper chip and the CPU side jumper chip ①.  
 B4923H; Remove the CPU side jumper chips ① and ②.

• LCD side: B4923G only.

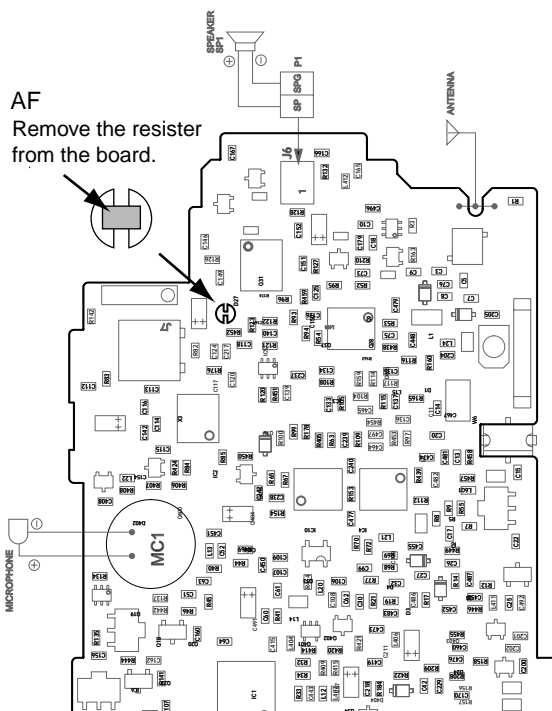

• CPU side

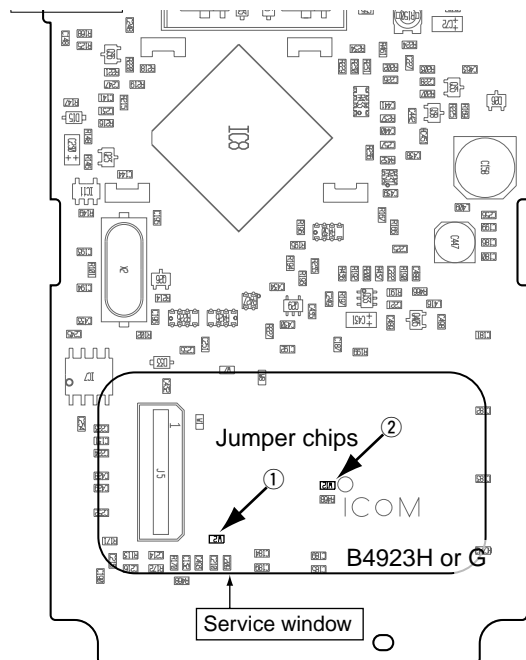

## APPENDIX -2; CLONING -1

### ■ Memory CH screen

Bnk	CTCSS/DTCSS	Text	PWR TOT	RF Lock	Auto	2Tone	Log	Scrambler		
1	FX	TX	Save	PWR out	Scan	Reset	Dec	IN/OFF	ON/OFF	Code
. 1			ON	H	Tag (Ena)	Tim-B		ON	25	
. 2			ON	ON	H	Tag (Ena)	Tim-B	OFF	ON	32
. 3								ON		
. 4								INH		
. 5										
. 6										

#### ◇ SCRAMBLER ON/OFF/INH

Turns the scrambler function "ON" or "OFF" as a initial setting. This item can also be turned "ON" or "OFF" with a program function switch when the function is assigned to a switch.

"INH": This means the scrambler function selection is inhibited.

Optional UT-109 or UT-110 Voice scrambler unit is required.

#### ◇ Scrambler code

Set the scrambler code number.

Selectable value;

UT-109: 1 to 32

UT-110: 1 to 255

\*Set the scrambler group code in the Common screen in advance. (UT-110 only)

### ■ Common 2 screen

Common 2	
PWR ON Password	OFF
Dealer Passcode	159357
Set Mode Access	Enabled
Transceiver Data Out	Enabled
Scrambler Group Code	4
Scrambler Type	Rolling
Synchronous Capture	Standard
Tone Start Timing	OFF

#### ◇ SCRAMBLER GROUP CODE (UT-110 only)

Set the scrambler group code.

➔ Selectable value; 1 to 4.

Optional scrambler unit (UT-110) is required.

**NOTE:** This setting is invalid for UT-109.

#### ◇ SCRAMBLER TYPE (UT-110 only)

Set the UT-110 Rolling type scrambler as UT-109 Non-rolling type. As UT-110 and UT-109 have different code settings, they are not compatible.

By selecting Non-rolling type in this item, you can use UT-110 as UT-109.

➔ Selectable value;

Rolling type (UT-110 normal)

Non-rolling type (UT-110 functions as UT-109)

**NOTE:** This setting is invalid for UT-109.

**NOTE:** The following setting will be invalid: Scrambler Group Code

#### ◇ SYNCHRONOUS CAPTURE (UT-110 only)

"Synchronous capture mode" is useful when communicating through a repeater. However, because of voice components, the transceiver can not maintain synchronous mode in rare cases.

Normally it is best to set this item to "Standard".

➔ Selectable value;

Standard (Normal operation)

Continuous (repeater operation)

#### ◇ TONE START TIMING (UT-110 only)

Tone start timing selects the synchronous tone signal transmit delay time.

Set the delay time when the other party's transceiver has power save mode.

➔ Selectable value; OFF(default)  
0.300s, 0.600s, 1.100s

## APPENDIX-2; CLONING NOTES (CS-F3 and CS-F300/S)

### ■ Setting examples

Below examples are not always needed settings, but will be useful in cases after transmitting a synchronous tone to notify operator of times to start talking.

### ■ IC-F3/F4/S series

- ➔ Generally, channels with voice scrambler settings should have the **power save function** in the Memory CH screen turned **OFF**.
- ➔ When you want to use the voice scrambler function on channels in which the power saver function is ON, set the Tone Start Timing in the Common screen to 1.100.

#### • For LMR:

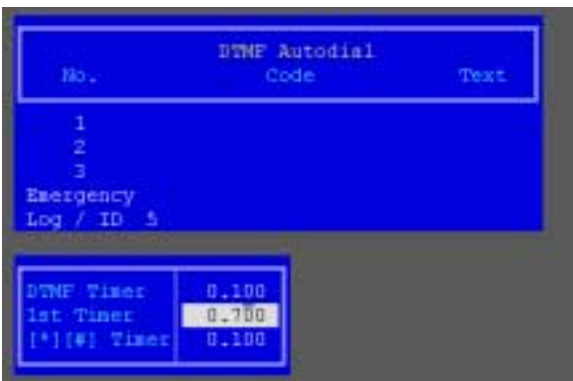

- ➔ In the Common 2 screen, set the Tone Start Timing to 1.100.
- ➔ In the DTMF Autodial screen, set the LOG/ID code to 5 and the 1st Timer to 0.700.
- ➔ In the memory CH screen, set necessary channels to LOG IN (L-IN).

**NOTE:** At these settings, when the period from pushing PTT to when you can talk seems long, set the 2nd timer in the Expert screen to OFF and set the Tone Start Timing to 0.600.

- ➔ In the DTMF Autodial screen, set the 1st Timer to 0.200.

#### • For PMR:

CH No.	TX Code	Input Edge	Op-Mode	ABC Data	ABC Del	ABC Sel	TX Code Channel
1	1	45	ON				Long Tone Timer 0.600
2	22222	45	ON				Line 6 Timer 0.600
3	33333	45	ON				Line 1 Timer 0.600
4	44444	45	ON				Line 2 Timer 0.600
5	55555	45	ON				Lead out Delay Timer 0.200
6	66666	45	ON				ABC Decode Times 1.600
7	77777	45	ON				Displayed Digit 12345
8	88888	45	ON				Special Tone (Group) A
9	99999	45	ON				(Reject) S
10	08808	45	ON				(Link2) T
11	08808	45	ON				PTT Call at Resubmit OFF
12	08808	45	ON				

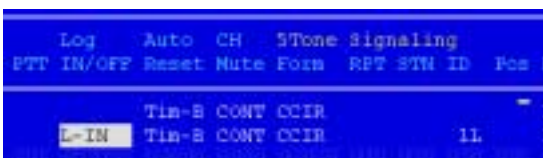

- ➔ In the Common 2 screen, set the Tone Start Timing to 1.100.
- ➔ In the TX Code CH screen, set CH NO.1 to 1 only.
- ➔ In the TX Code Common screen, set the Long Tone Timer to 0.300.
- ➔ In the memory CH screen, set necessary channel ID's to 1L (push space key to turn the Long Tone ON/OFF). (CCIR 5-tone format)
- ➔ In the memory CH screen, set necessary channels to LOG IN.

**NOTE:** At above settings, when the period from pushing PTT to when you can talk seems long, set the 2nd timer in the Expert screen to OFF and set the Tone Start Timing to 0.600.

- ➔ In the memory CH screen, return necessary channel ID's to 1 from 1L.

### ■ Other notes

- ➔ For communication between F300/F400/S series and F3/F4/S series, make sure that the F3/F4/S series power saver settings are set to the same values as the F300/F400/S series Tone Start Timing settings.

- ➔ When using the UT-109/UT-110 for non-rolling type scrambling there are 32 available scramble codes. In the memory CH screen, 1 to 255 can be input as codes however, many of these codes are identical (adding 32 to a code results in the same scramble code). The following groups of codes are the same:

1	to	32
(33	to	64)
(65	to	96)
(97	to	128)
(129	to	160)
(161	to	192)
(193	to	224)
(225	to	255)

- ➔ When using the UT-110 for rolling type scrambling similar but different codes will often result in a match. To avoid this, use codes that are sufficiently different (generally speaking codes that are separated by values of 20 or more will not match).

- ➔ When using the UT-110 for rolling type scrambling and a channel is in the scramble ON condition, if a received signal includes no simultaneous tone, the receiving station automatically enters the through condition and the transmission can be monitored. However, when non-rolling type scrambling is set, simultaneous tone are not used and therefore signals from other stations are received with modulation reversed.

## APPENDIX -3; IC-F3GT/GS, IC-F4GT/GS SERIES PRECAUTIONS

- UT-109 and UT-110 scrambler units require some PC board modifications. (See below.)
- IC-F3GT/GS, IC-F4GT/GS series require a #01: Low level type scrambler unit. Do not install the wrong version, as they are not compatible.
- The UT-110 may function as the UT-109 through cloning software.
- Compatible cloning software: CS-F3G.

### PC BOARD MODIFICATION

#### ■ Cut junction patterns

Cut the junction patterns before install the scrambler unit.

- ① Take off the optional connector access cover.
  - Insert a screwdriver into the hollow of the chassis, then lift and take away the cover. (The cover can not be used again.)
- ② Cut the patterns which marked C and F.
- ③ Install the unit as shown in the right.
- ④ Remove the paper backing of 2251 OPT sheet supplied as accessory.
- ⑤ Attach the new 2251 OPT sheet to the service window.
- ⑥ Program the necessary information with the cloning software before operation.

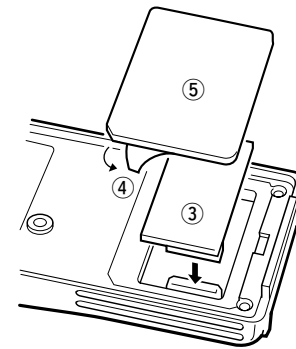
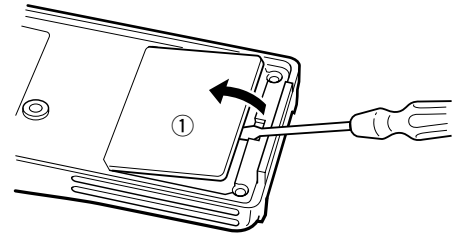

### CLONING

- Program the scrambler function ON/OFF/Inhibit and scrambler codes on the Edit Memory CH screen, Scrambler type\*, Group code\*, Synchronous Capture mode\* and Tone Start Timing\* on the [Common 2] screen with cloning software when installing this unit. (\*UT-110 only)
- Assign the scrambler function to a programmable key as "Scrambler" on Key & Display Assign screen, if required.
- Operation with the [SCRM] key:
  - Push and hold to turn the voice scrambler function ON.
  - Push to turn the voice scrambler function OFF.

### NOTE FOR REMOVAL

Be sure to resolder above disconnected points, otherwise no TX modulation or AF output is available when you remove the scrambler units.

# IC-F3GT/GS, IC-F4GT/GS SERIES MODIFICATION POINTS

**■ Model: IC-F3GT/GS**

**• Modification points. (C and F)**

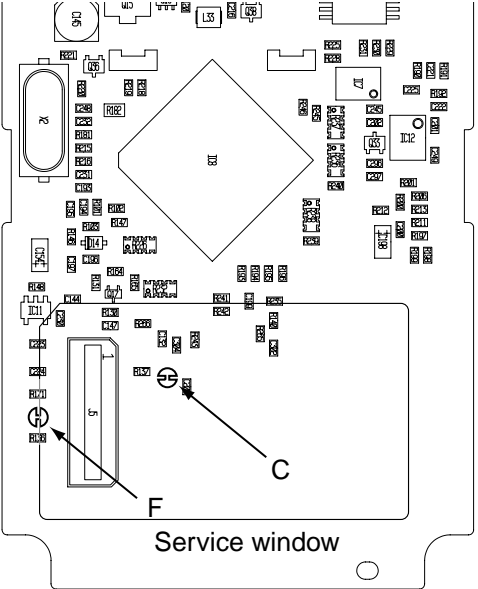

**• Cut the junction patterns C and F on the PC board.**

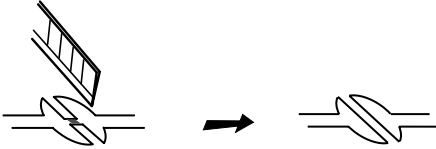

**■ Model: IC-F4GT/IC-F4GS**

**• Modification points. (C and F)**

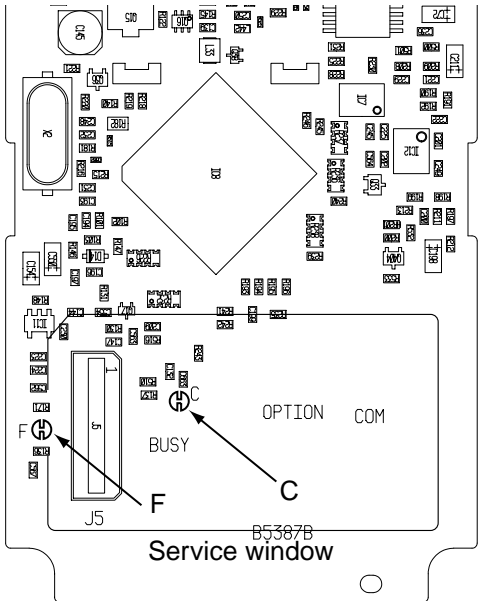

**• Cut the junction patterns C and F on the PC board same as above.**



## ■ Edit Memory CH screen

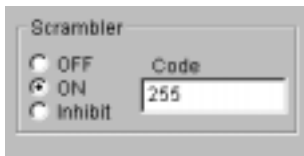

### ◇ SCRAMBLER ON/OFF/Inhibit

Turns the scrambler function "ON" or "OFF" as a initial setting. This item can also be turned "ON" or "OFF" with a program function switch when the function is assigned to a switch.

"Inhibit": This means the scrambler function selection is inhibited.

### ◇ Scrambler code

Set the scrambler code number.

Selectable value;

UT-109: 1 to 32

UT-110: 1 to 255

\*UT-110 requires to set the scrambler group code (1 to 4) in the Common 2 screen. Use the same Group Code and Scrambler code for same group.

## ■ Common 2 screen



### ◇ SCRAMBLER TYPE (UT-110 only)

Set the UT-110 Rolling type scrambler as UT-109 Non-rolling type. As UT-110 and UT-109 have different code settings, they are not compatible.

By selecting Non-rolling type in this item, you can use UT-110 as UT-109.

➔ Selectable value;

Rolling type (UT-110 normal)

Non-rolling type (UT-110 functions as UT-109)

**NOTE:** This setting is invalid for UT-109.

### ◇ SCRAMBLER GROUP CODE (UT-110 only)

UT-110 has 1020 (4 groups x 255) code numbers for providing higher communication security. Use the same scrambler group code for same group.

➔ Selectable value; 1 to 4.

**NOTE:** This setting is invalid for UT-109.

### ◇ SYNCHRONOUS CAPTURE (UT-110 only)

"Synchronous capture mode" is useful when communicating through a repeater. However, because of voice components, the transceiver can not maintain synchronous mode in rare cases.

Normally it is best to set this item to "Standard".

➔ Selectable value;

Standard (Normal operation)

Continuous (repeater operation)

### ◇ TONE START TIMING (UT-110 only)

Tone start timing selects the synchronous tone signal transmit delay time.

Set the delay time when the other party's transceiver has power save mode.

➔ Selectable value;

OFF(default)

0.300s, 0.600s, 1.100s

## IC-F3GT/GS, IC-F4GT/GS SERIES CLONING NOTES

### ■ Setting examples

Below examples are not always needed settings, but will be useful in cases after transmitting a synchronous tone to notify operator of times to start

### ■ IC-F3GT/GS, IC-F4GT/GS series

- ➔ Generally, channels with voice scrambler settings should have the **power save function** in the Edit Memory CH screen turned **OFF**.
- ➔ When you want to use the voice scrambler function on channels in which the power saver function is ON, set the Tone Start Timing in the Common 2 screen to 1.100.
  - In above case, non-scrambling voice will be transmitted approx. 1 sec. after pushing PTT.

When using the UT-110 as rolling type scrambler unit to keep the highest level of privacy, the 'LOG IN' function provides full time scrambling communications.

### ■ Using 'LOG IN' function

#### • For LMR:

- ➔ In the Common 2 screen, set the Tone Start Timing to 1.100.
- ➔ In the DTMF Autodial screen, set the LOG/ID code to 5 and the 1st Timer to 0.700.
- ➔ In the memory CH screen, set necessary channels to LOG IN (L-IN).

**NOTE:** At these settings, when the period from pushing PTT to when you can talk seems long, set the Power Save Start timer (2nd) in the Expert screen to "0.000" and set the Tone Start Timing in the Common 2 screen to 0.600.

- ➔ In the DTMF Autodial screen, set the 1st Timer to 0.200.

#### • For PMR:

- ➔ In the Common 2 screen, set the Tone Start Timing to 1.100.
- ➔ In the TX Code CH screen, set CH NO.1 to 1 only.
- ➔ In the 5Tone setting screen, set the Long Tone Timer to 0.300.
- ➔ In the Edit Memory CH screen, set necessary channel ID's to 1L (click check box to turn the Long Tone ON). (CCIR 5-tone format)
- ➔ In the memory CH screen, set necessary channels to LOG IN (L-IN).

**NOTE:** At above settings, when the period from pushing PTT to when you can talk seems long, set the Power Save Start timer (2nd) in the Expert screen to 0.000 and set the Tone Start Timing to 0.600.

- ➔ In the memory CH screen, return necessary channel ID's to 1 from 1L.

### ■ Other notes

- ➔ For communication between F300/F400/S series and F3GT/GS, F4GT/GS series, make sure that the F3GT/GS, F4GT/GS series power saver settings are set to the same values as the F300/F400/S series Tone Start Timing settings.

- ➔ When using the UT-109/UT-110 for non-rolling type scrambling there are 32 available scramble codes. In the memory CH screen, 1 to 255 can be input as codes however, many of these codes are identical (adding 32 to a code results in the same scramble code). The following groups of codes are the same:

1	to	32
(33	to	64)
(65	to	96)
(97	to	128)
(129	to	160)
(161	to	192)
(193	to	224)
(225	to	255)

- ➔ When using the UT-110 for rolling type scrambling similar but different codes will often result in a match. To avoid this, use codes that are sufficiently different (generally speaking codes that are separated by values of 20 or more will not match).

- ➔ When using the UT-110 for rolling type scrambling and a channel is in the scramble ON condition, if a received signal includes no simultaneous tone, the receiving station automatically enters the through condition and the transmission can be monitored. However, when non-rolling type scrambling is set, simultaneous tone are not used and therefore signals from other stations are received with modulation reversed.

## APPENDIX-4; IC-F1010/F1020/F2010/F2020 SERIES MODIFICATION POINTS

■ Model: IC-F1000/F2000 series

Cut the junction patterns on Main board AFO and MIC.

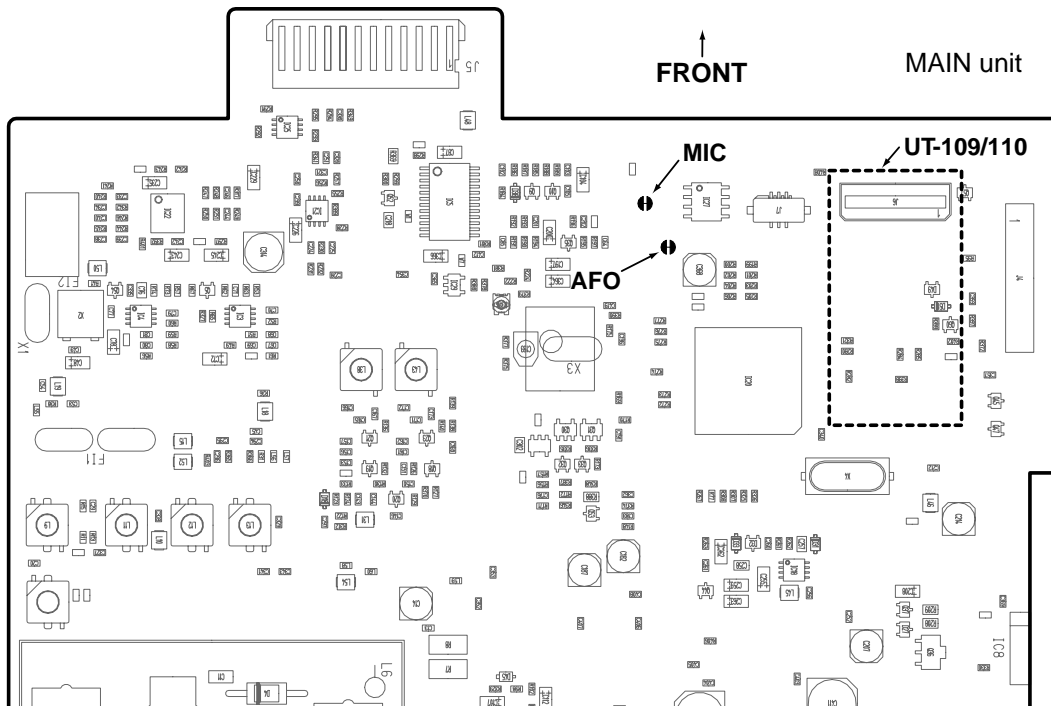

## CLONING

- UT-109 and UT-110 scrambler units require some PC board modifications. (See above **MIC** and **AFO**.)
- IC-F1010/F1020, IC-F2010/F2020 series require a **#02: High AF level type** scrambler unit. Do not install the wrong version, as they are not compatible.
- The UT-110 may function as the UT-109 through cloning software.
- Compatible cloning software: CS-F1000 Rev.2.2.
- Program the scrambler function OFF/ON/INH and scrambler codes on the Memory Channel screen, Scrambler Type\*, Group Code\*, Synchronous Capture\* and Tone Start Timing\* on the [Common 2] screen with cloning software when installing scrambler unit. (\*UT-110 only)
- Assign the scrambler function to a programmable key as "Scrambler" on [Key & Display Assign] screen, if required.
- Operation with the [Scrambler] key:
  - Push and hold to turn the voice scrambler function ON.
  - Push to turn the voice scrambler function OFF.
- Please refer the "IC-F3/F4/S SERIES CLONING PRECAUTIONS" on p. 3.

## NOTE FOR REMOVAL

/// Be sure to resolder above disconnected points, otherwise no TX modulation or AF output is available when you remove the scrambler units.

## APPENDIX -4; IC-F30/F31GT/GS, IC-F40/F41GT/GS SERIES PRECAUTIONS

- UT-109 and UT-110 scrambler units require some PC board modifications. (See below and next.)
- IC-F30/F31GT/GS, IC-F40/F41GT/GS series require a **#02: High AF level type** scrambler unit. Do not install the wrong version, as they are not compatible.
- The UT-110 may function as the UT-109 through cloning software.
- Compatible cloning software: CS-F30G.

## OPTIONAL UNIT INSTALLATION

### Installation

Disassemble the some parts before install the scrambler unit.

- ① Unscrew nut **(a)**, and remove the knobs.
- ② Unscrew screw **(b)** and 2 screws **(c)**, then remove the multi-connector cover and rear panel.
- ③ Unscrew 2 screws **(d)**, then remove the multi-connector.
- ④ Unscrew 2 screws **(e)**, then take off the chassis from the front panel in the direction of the arrow.

#### Be careful!

Flat cable is connected between the MAIN unit on the chassis and front panel.

- ⑤ Install the desired optional unit. Insert tightly to avoid bad contact.

**NOTE:** When installing UT-105 or UT-111, the unit **MUST BE** plugged into **OPT1**. Otherwise the unit will not work correctly. (Other optional units can be plugged into either slot.)

- ⑥ Program the necessary information with the cloning software before operation.

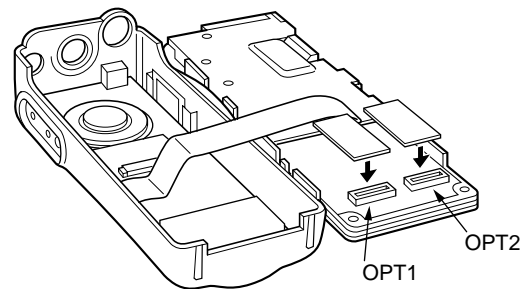
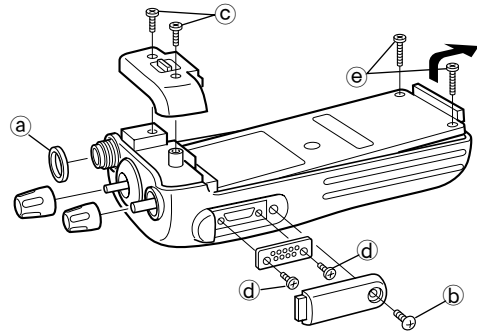

## CLONING

- Program the scrambler function ON/OFF/Inhibit and scrambler codes on the Edit Memory CH screen, Scrambler type\*, Group code\*, Synchronous Capture mode\* and Tone Start Timing\* on the [Common 2] screen with cloning software when installing scrambler unit. (\*UT-110 only)
  - Assign the scrambler function to a programmable key as "Scrambler" on Key & Display Assign screen, if required.
  - Operation with the [Scrambler] key:
    - Push and hold to turn the voice scrambler function ON.
    - Push to turn the voice scrambler function OFF.
- Please refer the "IC-F3GT/GS, IC-F4GT/GS SERIES CLONING NOTES" on p. 10.

## NOTE FOR REMOVAL

Be sure to resolder disconnected points, otherwise no TX modulation or AF output is available after you remove the scrambler units.

## MODIFICATION POINTS

- Modification points. (Both IC-F30/F31GT/GS, F40/F41GT/GS)
- Cut the junction patterns A and B on the MAIN unit.

