

NO	DESCRIPTION	MATERIAL	Q'TY	FINISH	REMARK
1	BODY 1	BRASS	1	NICKEL	B-SMA0065-N
2	INSULATION	TEFLON	1	TEFLON	I-0306T
3	BODY 2	BRASS	1	NICKEL	B-N0651-N
4	INSULATION	TEFLON	1	TEFLON	I-0283T
5	WASHER	BRASS	1	NICKEL	W-0014
6	RUBBER	SI RUBBER	1	RUBBER	RU-0007
7	PIN	PH.BRONZE	1	GOLD	P-SMA0431-G
8	BODY 3	BRASS	1	NICKEL	B-N0032-N
9	BODY 4	BRASS	1	NICKEL	B-N0033-N

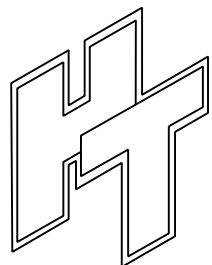
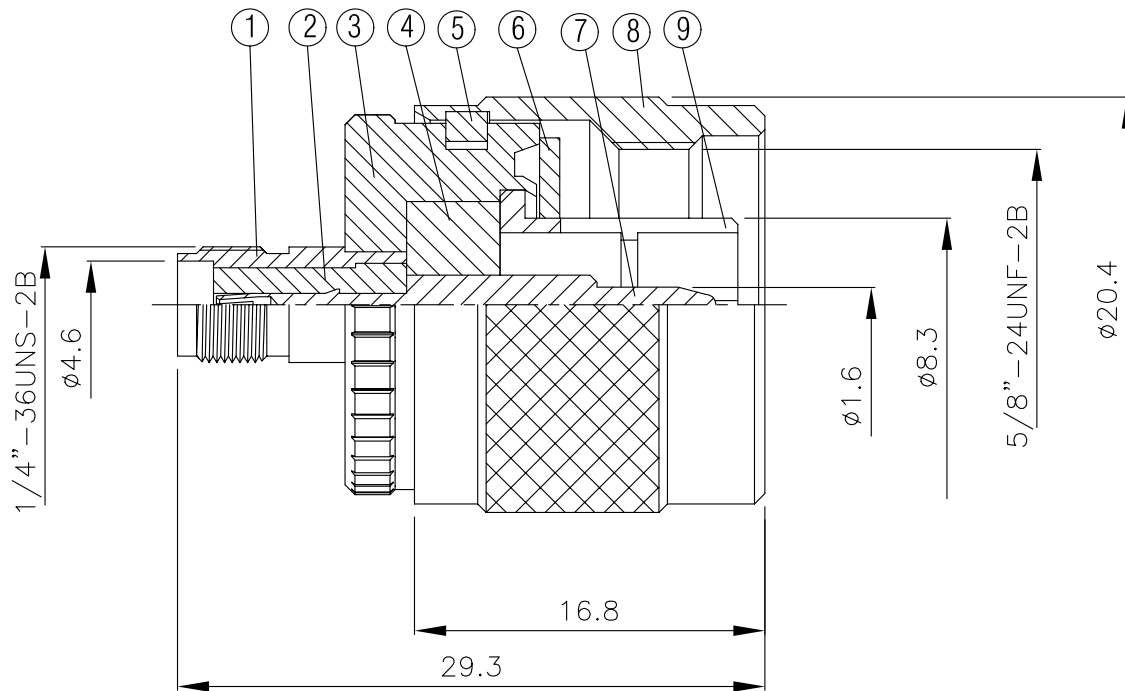
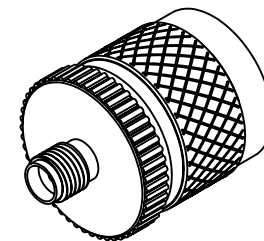

HUS-TSAN GROUP CO., LTD.

P.O. BOX 40-76. TAINAN. TAIWAN, R.O.C.

TITLE SMA FEMALE N MALE ADAPTOR

PART NO. SMA-23-TGN

DRAWING NO. SMA 23 TGN

DRAWN MARY DATE 96.03.27

CHECKED 蘇姿潔 DATE

Q.A. 馮健華 DATE

APPROVAL 徐燦霖 DATE

REVISION DATE

DIMENSIONS ARE IN MILLIMETERS

UNLESS OTHERWISE SPECIFIED TOLERANCE

0.5-5=±0.2	120-315=±1
5-30=±0.4	315-1000=±1.6
30-120±0.6	1000-2000=±2.4

SCALE 4:1 SIZE A

REVISION

DESCRIPTION	ENGINEER