

DISCLAIMER

Information in this manual is designed for **user purposes only** and is **not** intended to supersede information contained in customer regulations, technical manuals/documents, positional handbooks, or other official publications. The copy of this manual provided to the customer will **not** be updated to reflect current data.

Customers using this manual should report errors or omissions, recommendations for improvements, or other comments to MFJ Enterprises, 300 Industrial Park Road, Starkville, MS 39759. Phone: (662) 323-5869; FAX: (662) 323-6551. Business hours: M-F 8-4:30 CST.

Autoryzowany Przedstawiciel MFJ w Polsce:

abel & **profit**
centrum radiokomunikacji

INRADIO
ABEL & PRO-FIT Centrum Radiokomunikacji
ul. Puszkina 80 92-516 Łódź Poland
tel. (+42) 649 28 28 fax: (+42) 677 04 71
e-mail: biuro@inRADIO.pl
internet: www.inRADIO.pl

TABLE OF CONTENTS

<u>TOPIC</u>	<u>PAGE</u>
TABLE OF CONTENTS	ii
LIST OF FIGURES	ii
LIST OF TABLES	ii
RF HAZARD PRECAUTIONS	1
INTRODUCTION & SYSTEM FEATURES	7
SYSTEM DESCRIPTION	10
LOOP THEORY	12
SYSTEM SETUP	14
LOOP CONSTRUCTION	15
SYSTEM OPERATION	17
FAST START INSTRUCTIONS	20
TECHNICAL ASSISTANCE	23

LIST OF FIGURES

Figure 1 The Electromagnetic Spectrum	2
Figure 2 MFJ-936B Loop Tuner™	8
Figure 3 MFJ-936B Loop Tuner™ w/ MFJ-57B PVC Cross Loop Kit Installed	9
Figure 4 MFJ-936B Loop Tuner™ Front Panel Controls & Indicators	10
Figure 5 MFJ-936B Loop Tuner™ Rear Panel Connectors	11
Figure 6 Typical MFJ-936B Loop Tuner™ Setup Configuration	14

LIST OF TABLES

Table 1 Indoor & Outdoor Operating Environments at 100 Watts	5
Table 2 Indoor & Outdoor Operating Environments at 150 Watts	6
Table 3 MFJ-936B Most Efficient Single-band Loop Lengths	15
Table 4 MFJ-936B Convenient Multi-band Loop Lengths	15

RF HAZARD PRECAUTIONS

RF HAZARD BACKGROUND INFORMATION

The following WARNING is labeled on the MFJ-936B *LOOP TUNER*™ Rear Panel:

WARNING

DO NOT touch or come into contact with *Loop Connectors* or *Loop Antenna* while transmitting

YOU CAN BE SERIOUSLY INJURED !!!

Using the MFJ-936B *Loop Tuner*™ can, and in fact does, produce LETHAL voltages and HIGH CURRENTS during normal operation. The Hi-Q circuit produced by resonating the wire loop connected to the tuner, and matching it to the 50-Ohm coax supplying power creates this unique operating environment.

NOTICE

It is imperative that the operator specifically follows operating instructions and complies with all **CAUTIONS, WARNINGS, and FCC Guidelines for Human Exposure to Radio frequency (RF) Electromagnetic Fields**

Radio frequency (RF) Radiation

Radio frequency (RF) energy is one type of electromagnetic energy. Electromagnetic waves and associated phenomena can be discussed in terms of energy, radiation or fields. Electromagnetic "radiation" is defined as waves of electric and magnetic energy moving together (i.e., radiating) through space. The movement of electrical charges generates these waves. For example, the movement of charge in a radio station antenna (the alternating current) creates electromagnetic waves radiating away from the antenna and intercepted by receiving antennas. Electromagnetic "field" refers to the electric and magnetic environment existing at some location due to a radiating source such as an antenna.

RF HAZARD PRECAUTIONS

An electromagnetic wave is characterized by its wavelength and frequency. The wavelength is the distance covered by one complete wave cycle. The frequency is the number of waves passing a point in a second. For example, a typical radio wave transmitted by a 2-meter VHF station has a wavelength of about 2 meters and a frequency of about 145 million cycles per second (145 million Hertz): one cycle/second = one Hertz, abbreviated Hz.

Electromagnetic waves travel through space at the speed of light. Wavelength and frequency are inversely related by a simple equation: (frequency) times (wavelength) = the speed of light. Since the speed of light is a constant quantity, High Frequency (HF) electromagnetic waves have short wavelengths, and Low-Frequency (LF) waves have long wavelengths. Frequency bands used for amateur radio transmissions are usually characterized by their approximate corresponding wavelengths, e.g., 12, 15, 17, 20 meters, etc.

The electromagnetic "spectrum" includes all of the various forms of electromagnetic energy ranging from extremely low frequency (ELF) energy (with very long wavelengths) to all the way up to X-rays and gamma rays, which have very high frequencies and correspondingly short wavelengths. In between these extremes lie radio waves, microwaves, infrared radiation, visible light and ultraviolet radiation, respectively. The RF part of the electromagnetic spectrum can generally be defined as that part of the spectrum where electromagnetic waves have frequencies that range from about 3 kilohertz (kHz) to 300 gigahertz (GHz). Figure 1 illustrates the electromagnetic spectrum.

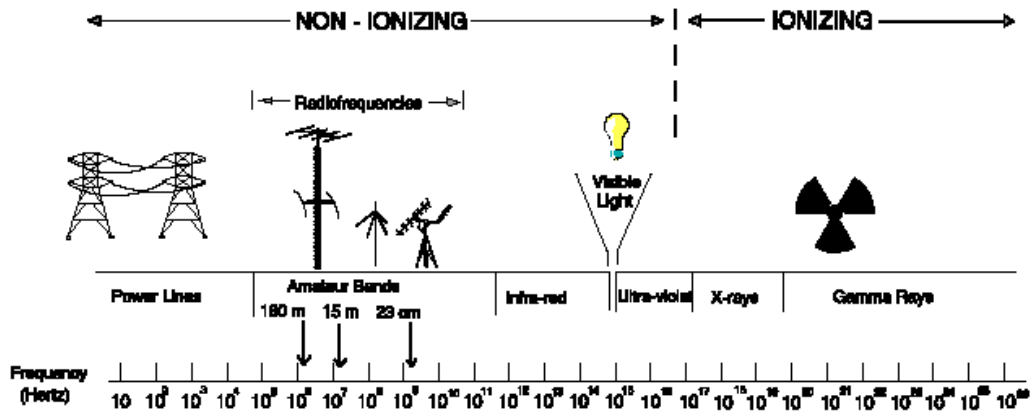

Figure 1 The Electromagnetic Spectrum

RF HAZARD PRECAUTIONS

FCC OET Bulletin 65, Supplement B, *Evaluating Compliance with FCC Guidelines for Human Exposure to Radio frequency Electromagnetic Fields.*

The FCC Office of Engineering Technology (OET) Bulletin 65, Supplement B, *Evaluating Compliance with FCC Guidelines for Human Exposure to Radio frequency Electromagnetic Fields* impacts directly the use and operation of the MFJ-936B Loop Tuner™. It establishes safe operating distances from the loop antenna and associated power levels in order to permit the operator and persons that may be impacted by operation to exist in a safe, RF radiation hazard-free environment. Guidelines for Maximum Permissible Exposure (MPE) are defined in Supplement B of the bulletin.

IMPORTANT NOTE

Use Supplement B in connection *with* FCC OET Bulletin 65, Version 97-01. The information in the supplement provides additional detailed information used for evaluating compliance of amateur radio stations with FCC guidelines for exposure to radio frequency electromagnetic fields. However, Supplement B users should also consult Bulletin 65 for complete information on FCC policies, guidelines and compliance-related issues. Definitions of terms used in this supplement appear in Bulletin 65. Bulletin 65 can be viewed and downloaded from the FCC's Office of Engineering and Technology's World Wide Web Internet Site:

<http://www.fcc.gov/oet/rfsafety>

OPERATING ENVIRONMENTS

Under some circumstances, such as an antenna located unusually near humans, an indoor antenna in a living space, or a balcony-mounted antenna a foot or so away from a neighbor's balcony, the FCC could require a station evaluation or take other action. Computer models of small HF loops, for example, yield RF fields very near the antenna that are much higher than the standard amateur radio station outdoor antenna installation yields. Therefore, when you use the MFJ-936B Loop Tuner™ in your Ham Shack, at a portable location (outdoors), or one such as a hotel/motel room care must be taken **not** to exceed established MPE to yourself and others who may encounter the RF field associated with your operation.

RF HAZARD PRECAUTIONS

RF RADIATION EXPOSURE CONCERNS

Controlled population exposure limits apply to amateur licensees and members of their immediate household (but **not** their neighbors - see next paragraph). In general, a controlled environment is one for which access is controlled or restricted.

In the case of a fixed or portable amateur station, the licensee or grantee is the person responsible for controlling access and providing the necessary information and training as described in FCC OET Bulletin 65, Supplement B.

General population/uncontrolled exposure limits apply to situations in which the general public may be exposed, or in which persons who are exposed as a consequence of their employment, such as hotel/motel employees or overnight residents, may **not** be made fully aware of the potential for exposure or cannot exercise control over their exposure. Therefore, members of the *general public* always fall under this category when exposure is **not** employment-related, as in the case of residents in an area near a broadcast tower. Neighbors of amateurs and other non-household members would normally be subject to the general population/uncontrolled exposure limits.

OPERATING ENVIRONMENTS & GUIDELINES

Table 1 and Table 2 lists MFJ-936B Loop Tuner™ operating environments, average power level, and safe distances that should provide compliance with the FCC's MPE recommendations/standards for controlled and uncontrolled populations. Distance data listed is a result of computer-modeling a *circular loop*, which is the most efficient radiator configuration. Parameters used include those listed below:

- *Loop perimeter or circumference* (75% of a quarter wave loop in length for each band)
- *Diameter of loop conductor* (approximately 4mm/10 gauge)
- *Height of lowest section of loop above ground* (1 and 3 meters feed-point heights)
- *Operating frequencies* (7.175, 10.1, 14.2, 18.1, 21.2, 24.95, & 28.5 MHz)
- Output power in watts (100 Watts average for Table 1 and 150 Watts average for Table 2)

RF HAZARD PRECAUTIONS

Table 1 Indoor & Outdoor Operating Environments at 100 Watts

Freq (MHz)	Controlled Population Exposure		Uncontrolled Population Exposure		Output Power (Watts)
	(Distance in feet/meters)		(Distance in feet/meters)		
7.0 ₁	1.2	0.36	2.0	0.51	100
7.0 ₂	1.2	0.38	2.1	0.75	100
10.0 ₁	1.9	0.57	3.0	0.75	100
10.0 ₂	2.3	0.69	3.6	0.92	100
14.0 ₁	2.4	0.72	3.8	0.96	100
14.0 ₂	2.5	0.77	4.6	0.96	100
18.0 ₁	2.8	0.85	5.1	1.06	100
18.0 ₂	2.9	0.87	5.2	1.08	100
21.0 ₁	3.0	0.92	5.9	1.23	100
21.0 ₂	3.1	0.93	6.0	1.50	100
24.0 ₁	3.2	0.98	6.6	1.66	100
24.0 ₂	3.3	1.02	6.6	1.67	100
28.0 ₁	3.4	1.05	7.2	1.83	100
28.0 ₂	3.4	1.05	7.3	1.83	100

₁ MFJ-936B Loop Tuner™ located at *one meter* in height above ground level.

₂ MFJ-936B Loop Tuner™ located at *three meters* in height above ground level.

RF HAZARD PRECAUTIONS

Table 2 Indoor & Outdoor Operating Environments at 150 Watts

Freq (MHz)	Controlled Population Exposure		Uncontrolled Population Exposure		Output Power (Watts)
	(Distance in feet/meters)		(Distance in feet/meters)		
7.0 ₁	1.4	0.44	2.0	0.62	150
7.0 ₂	1.5	0.46	2.1	0.91	150
10.0 ₁	2.3	0.69	3.0	0.91	150
10.0 ₂	2.7	0.84	3.6	1.11	150
14.0 ₁	2.8	0.87	3.8	1.16	150
14.0 ₂	3.0	0.93	4.6	1.40	150
18.0 ₁	3.4	1.03	5.1	1.56	150
18.0 ₂	3.4	1.05	5.2	1.59	150
21.0 ₁	3.7	1.12	5.9	1.80	150
21.0 ₂	3.7	1.13	6.0	1.82	150
24.0 ₁	3.9	1.19	6.6	2.01	150
24.0 ₂	4.1	1.24	6.6	2.02	150
28.0 ₁	4.2	1.27	7.2	2.22	150
28.0 ₂	4.2	1.27	7.3	2.22	150

¹MFJ-936B Loop Tuner™ located at *one meter* in height above ground level.

²MFJ-936B Loop Tuner™ located at *three meters* in height above ground level.

INTRODUCTION & FEATURES

MFJ-936B LOOP TUNER™ INTRODUCTION

The MFJ-936B *Loop Tuner*™ is a small, versatile, high-efficiency device that turns any wire loop into a high-efficiency multi-band transmitting loop antenna system designed for 50-ohm use at 150 Watts maximum input (all modes). It consists of two functional units:

- MFJ-936B *Loop Tuner*™
- Wire Loop(s) (not included)

One function of the MFJ-936B *Loop Tuner*™ tunes/resonates various lengths of wire into a very Hi-Q tuned-circuit used as a transmitting loop antenna. It uses an MFJ low-loss *Butterfly* capacitor with no rotating contacts (available separately) in this circuit. The second function is a matching network that serves to match the Hi-Q transmitting loop circuit to any length of 50-Ohm coaxial cable.

No ground, radials, or counterpoise system is required or needed. The MFJ-936B *Loop Tuner*™ tunes any shape loop: circle, square, rectangle or any odd shape. However, a wire approaching a quarter wavelength shaped as a circle is the most efficient configuration.

The MFJ-936B *Loop Tuner*™ uses fixed wire lengths, which cover about 1.5 to 1 frequency ranges (i.e. 28 – 18 or 10 – 7 MHz, etc.). Exact frequency coverage depends on each individual installation configuration involving choice of wire length and diameter, shape of loop, *Loop Tuner*™ height above ground level, and operating environment. Figure 2 illustrates the MFJ-936B *Loop Tuner*™.

The MFJ-936B *Loop Tuner*™ mounts an assembled PVC Cross provided in the MFJ-57B Loop Antenna Kit by inserting the cross into a PVC receptacle mounted on the top of the unit's cover. This kit provides a means to operate 20 and 30 meters using an insulated 10-gauge flexible wire loop fitted with direct contact low-resistance lugs and strung on the PVC after assembly.

Assembly takes less than five minutes from packaged kit to ready for operation. Figure 3 illustrates the PVC Cross mounted on the MFJ-936B *Loop Tuner*™ in a typical outdoor operation environment. Care should be taken, however, to secure the loop if wind becomes a factor in the operating environment.

INTRODUCTION & FEATURES



Figure 2 MFJ-936B Loop Tuner™

MFJ-936B LOOP TUNER™ FEATURES:

- **Powerless:** No power supply required.
- **Maximum Input Power:** 150 Watts (all modes)
- **Internal SWR/Wattmeter:** Cross-needle meter measures forward power, reflected power and SWR. Push-button power range switch allows full-scale readings of 30 and 300 Watts forward power.
- **Easy-to-Read Loop RF Current Indicator:** 0 to 100 scale with adjustable sensitivity.
- **Easy-Carry Handle:** Permits easy handling to/from portable location(s)
- **Small Physical Profile:** 10 ¼" W, 9 ½" D, 5 ¼" H
- **Low Radiation Angle:** Rivals full size dipoles.
- **Quiet Reception:** Extremely quiet receiving antenna. Hi-Q rejects out-of-band interference, reduces overloading, and rejects harmonics.
- **Indoor Use:** Perfect for apartments & hotel/motel rooms, antenna restricted, and portable locations.

INTRODUCTION & FEATURES

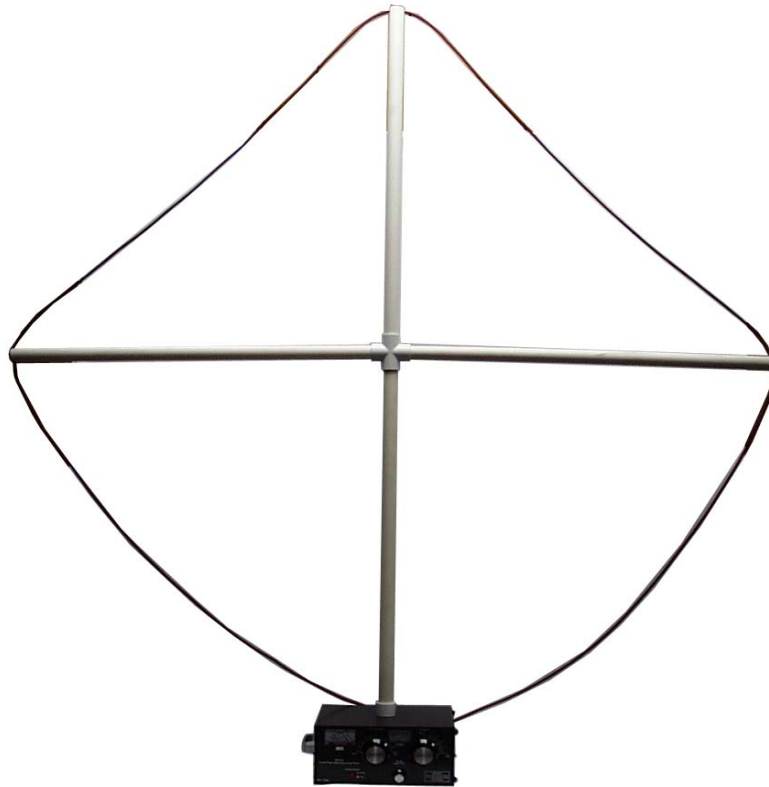

Figure 3 MFJ-936B Loop Tuner™ with MFJ-57B PVC Cross Loop Antenna Kit Installed

SYSTEM DESCRIPTION

MFJ-936B LOOP TUNER™ CONTROLS & INDICATORS

The MFJ-936B Loop Tuner™ Front Panel controls and indicators function to permit resonating the wire loop at the output, and matching the coaxial line impedance at the input of the tuner. Refer to Figure 4 and the numbered component locations.



Figure 4 MFJ-936B Loop Tuner™ Front Panel Controls and Indicators

- A Tuning control (1) permits adjustment of the Butterfly capacitor to peak/resonate the wire loop.
- A Matching control (2) matches the tuned loop circuit to a 50-Ohm coaxial cable.
- An Antenna Current Meter (3) indicates antenna current on a scale of 0-100, and is controlled by a Meter Sensitivity Control (4) located beneath the Antenna Current Meter.
- An internal SWR/Wattmeter (5) measures forward power, reflected power, and SWR.
- A push button Power Range Switch (6) allows the user to select between 30 and 300 Watts forward power.
- A PVC Mount (7) located on the enclosure top permits mounting of the PVC Cross Assembly.
- An easy-to-carry Handle (8) permits easy handling to/from portable locations.

SYSTEM DESCRIPTION

The MFJ-936B *Loop Tuner*™ Rear Panel connections function to permit connecting the wire loop at the output, and connecting the coaxial line at the input of the tuner. Refer to Figure 5 and the labeled component locations.



Figure 5 MFJ-936B *Loop Tuner*™ Rear Panel Connections

The loop antenna connects to the *Loop Connectors* (1) with the two wing nuts provided on the *Loop Connector* standoff rods. Care must be taken **not** to disturb the wires leading from the lugs on the *Loop Connector* stand-off rods and entering through the back of the tuner. These two *Loop Connector* connection points must be kept clean at all times. To minimize contact resistance, the loop wire is in direct contact with the low resistance soldered lug.

When **not** in use for periods of time, always clean the connectors before re-attaching loop antennas of any kind. This unit is **not** intended for outdoor installation except during portable operation and must be protected from the elements.

Coaxial line connects to the SO-239 connector labeled *Transmitter* (2) providing RF power input to the tuner. The **WARNING** label must be obeyed!

LOOP THEORY

LOOP ANTENNA BACKGROUND INFORMATION

A small loop antenna is one that is characterized by low-noise reception, works well even when mounted at ground level, and has a conductor length or circumference of less than 1/3 wavelength. The ideal small transmitting antenna would have performance equal to a large antenna, and a small loop antenna approaches that performance. Bandwidth is quite narrow due to the extreme hi-Q of the tuned-circuit configuration when paired with a capacitor.

The components in a resonated transmitting loop are subjected to high currents and voltages because of the large circulating currents found in the high-Q tuned circuit formed by the antenna. It is very important that capacitors used in this antenna have a high RF current rating. Even a 100-W transmitter develops currents in the tens of amperes, and voltages across the tuning capacitor in excess of 10,000 V. This consideration also applies to any conductors used to connect the loop to the capacitor. A piece of #14 wire may have more resistance than the entire loop conductor! The best electrical connections possible, are those using soldered or welded joints.

The heart of the MFJ-936B *Loop Tuner*™ is the “Butterfly” loop-tuning capacitor, which has no rotating contacts. When coupled to a low-resistance loop conductor, such as a copper strap, it provides a high efficiency-transmitting loop.

As the loop antenna is elevated, its efficiency improves accordingly. When traveling, a room at some elevation above ground level makes for a better portable operation experience with the MFJ-936B *Loop Tuner*™. At very low heights, close coupling to the ground causes detuning and losses due to current induced into a mirror image of the loop below the surface with resistance of the image loop proportional to soil resistance. Another loss component is due to current flowing in the soil via capacitance between the loop and soil surface.

An operational height equal to 1/2 diameter of the loop antenna is recommended to prevent detuning and excess ground losses when using the MFJ-936B *Loop Tuner*™ loop antenna system. This means the tuner should be at that recommended height, since it is connected to the bottom (ends) of the loop, whatever the loop antenna configuration: Circle, Square, Hexagonal, etc.

For operation on the 14 MHz band and higher, ground losses are a minimum near ground, so it is fine to operate on the ground floor. For the 7 MHz band and lower, ground losses become significant on the ground floor. To reduce ground losses, operate on a second or third floor.

LOOP THEORY

For minimum ground loss when operating near ground, the loop should be mounted vertically. For higher elevations (relative to the wavelength), horizontal mounting will also give low ground losses.

Using *freeware*-modeling programs, it is possible to improve the efficiency of the loop antenna system by varying the parameters until you optimize your particular operational configuration, even while portable. One source example for free programs is G4FPQ's Web site: <http://www.btinternet.com/~g4fgq.regp/>.

SYSTEM SETUP

SYSTEM SETUP CONFIGURATION

The MFJ-936B *Loop Tuner*™ setup configuration is simple and consists of the following components:

- RF Generator (Transmitter/Transceiver; ~5 Watts minimum)
- MFJ-936B *Loop Tuner*™
- Coaxial cable(s)
- #10 gauge (or larger) stranded wire cut to approximately 75% of a $\frac{1}{4}$ wavelength at the chosen resonant frequency

Figure 6 is a block diagram of the typical MFJ-936B *Loop Tuner*™ setup configuration.

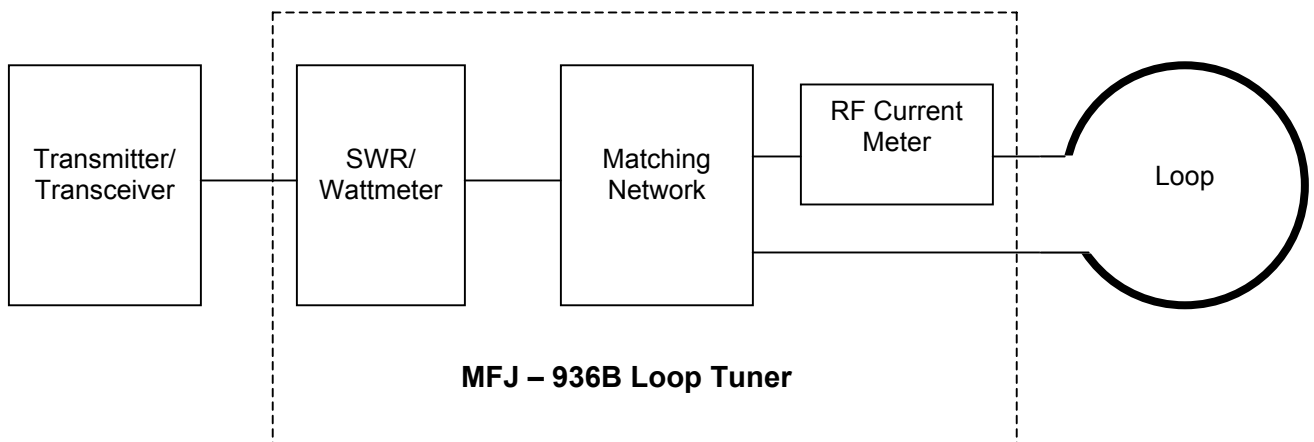

Figure 6 Typical MFJ-936B *Loop Tuner*™ Configuration

LOOP CONSTRUCTION

LOOP CONSTRUCTION

Loop construction for the MFJ – 936B Loop Tuner is reasonably simple, and Table 3 lists the maximum tunable length for the *most efficient* operation for the upper frequency limit of each band. Each length can be tuned lower in frequency. Exact frequency coverage depends on each individual installation configuration involving choice of wire length and diameter, shape of loop, *Loop Tuner™* height above ground level, and operating environment.

Table 3: MFJ – 936B Most Efficient Single-Band Loop Lengths

Band (meters)	Most Efficient Single-Band Loop Lengths (feet)
80	63.0
40	28.0
30	20.0
20	13.0
17	9.0
15	7.0
12	5.5
10	4.0

Table 4 lists the loop lengths for the *most convenient* band coverage. These lengths will allow the most frequency coverage for each loop.

Table 4: MFJ – 936B Convenient Multi-Band Loop Lengths

Band (meters)	Convenient Multi-Band Loop Lengths (feet)
40, 30	20.0
30, 20	13.0
30, 20, 17	9.0
20, 15	7.0
17, 15, 10	4.0

The loop can be constructed from wire, tubing, sheet, and an especially good material is 1" wide PC board. However, finding a piece of PC board long enough to form into a circular loop for 7.175 MHz may prove to be difficult! This leads us to the unique opportunity to **EXPERIMENT** while using the MFJ-936B *Loop Tuner™* to resonate the loop antenna you design.

The applications and parameters can be adjusted easily with the help of the *Freeware* programs previously mentioned, and you may choose to design a totally new and unique loop antenna for on-air experimentation. Designing an outdoor loop for a band such as 7 MHz could be a challenge and result in a very good radiator and especially good receiving antenna for DX-ing and/or rag-chewing. We, at MFJ, think the experimental aspects of the *Loop Tuner*™ are exciting, and can provide hours of quality operating, even at QRP levels.

SYSTEM OPERATION

MFJ-936B LOOP TUNER™ OPERATION

The most important aspect of using the MFJ-936B *Loop Tuner*™ is it opens-up opportunity for Hams to once again **experiment** while enjoying operating at the same time. Imagine how exciting it can be to establish contact with a distant station using an antenna that you designed for the first time. Even more so, what if you are just using a few watts, and the antenna is just a few feet away from your operating position *inside your home!*

Operation is simple, but must follow specific steps in a specific order. Moreover, you must have first consulted the RF Hazards section of this manual to ensure compliance with established standards for Minimum Permissible Exposure (MPE) to certain levels of RF radiation.

WARNING

DO NOT touch or come into contact with *Loop Connectors* or *Loop Antenna* while transmitting

YOU CAN BE SERIOUSLY INJURED !!!

Step 1

Place the MFJ-936B *Loop Tuner*™ at the chosen place of operation, and connect the loop antenna to the wing nut terminals on the rear panel.

Step 2

Using a pre-cut prepared wire and fasteners (non-conductive plastic clothespins for example) form a loop to enclose as much area as possible (for example, clothespin a wire loop to a curtain around a window frame). A circle encloses the maximum area. Otherwise, drape it across bookcases or similar objects to fashion a loop of sorts to use. If the loop antenna is rigid, then place the *Loop Tuner*™ in a position to accommodate its particular shape and size.

Step 3

Complete the typical MFJ-936B *Loop Tuner*™ setup configuration as illustrated in Figure 6 of this manual.

SYSTEM OPERATION

Step 4

Make the following preliminary settings on the controls of the Loop Tuner:

- TUNING control to position “0, Low Freq”.
- MATCHING control to position “10, Min C”.
- METER SENSITIVITY control to fully clockwise position.
- POWER RANGE switch position to “out, 30W range”.

Step 5

Tune the transceiver or receiver to the band and frequency of interest and “Ear-ball” tune the MFJ-936B Loop Tuner controls for maximum noise and S-Meter reading. “Ear-balling”, like “Ball-parking” is a term often used to describe the listening process as used to hear a “peak” in reception before actually applying a transmit signal to the tuner. The tuner will produce a peak when the proper positions for the controls are achieved. The normal process consists of the following suggested instructions:

- Slowly rotate TUNING control clockwise while listening for a peak until you reach position “5, High Freq.”
- If no peak is found, re-position TUNING control to “0, Low Freq.”
- Rotate MATCHING control counter-clockwise one position to “9”.
- Slowly rotate TUNING control clockwise while listening for a peak until you reach position “5, High Freq.”
- If no peak is found, re-position TUNING control to “0, Low Freq.”
- Rotate MATCHING control counter-clockwise one more position to “8”.
- Slowly rotate TUNING control clockwise while listening for a peak until you reach position “5, High Freq.”
- Repeat this sequence until the MATCHING control reaches position “0”.
- If no peak is found, the loop length is incorrect for the frequency of interest. (See Table 3 for the Most Efficient Loop Length for the frequency of interest.)
- Once a peak is found, alternately adjust TUNING and MATCHING controls until the peak is maximized.

Step 6

Apply 10 to 20 Watts of power to the MFJ – 936B Loop Tuner and adjust the TUNING control for maximum RF antenna current. Adjust the MATCHING

control for minimum SWR on the MFJ – 936B SWR/Wattmeter. Re-adjust the TUNING control for maximum RF antenna current. Repeat this sequence until you see no further improvement in minimum SWR and maximum antenna current. Always adjust for maximum RF antenna current as the final adjustment. Be sure to adjust the RF Antenna Current Meter using the METER SENSITIVITY control for center scale reading as you make adjustments.

Step 7

Once you are satisfied that the adjustments and settings are correct for minimum SWR and maximum antenna current, you can advance the power to 150 Watts if desired. Be sure to set the POWER RANGE switch to “in” for the 300-Watt scale. Be sure that MPE distance standard as defined in Supplement B of the FCC OET Bulletin 65, version 97-01 is met. Should any arcing be detected, stop transmitting and check connections and proximity to objects that may be suspect. If arcing seems to be inside of the MFJ – 936B, Loop Tuner, lower output power and re-check for arcing.

As a courtesy to our fellow hams, for safety and to keep within FCC regulations you should use the minimum power needed for communications. Power levels of 20 to 50 Watts often provide very reliable communications. The difference between 50 and 100 Watts is less than ½ S-Unit and is not noticeable on the receiving end.

Step 8

You can now enjoy operating in your favorite mode. However, if you change frequency more than about 5 KHz, you may find you’ll need to re-adjust the TUNING controls for minimum SWR. Rotate TUNING clockwise for higher frequencies and counter clockwise for lower frequencies. Even greater frequency excursions can cause the MATCHING control to also require adjustment.

This concludes the MFJ – 936B Loop Tuner System Operation instructions.

MFJ-936B Loop Tuner™ System Accessories

Two Kits are available for use with the MFJ-936B Loop Tuner™, and each enables the operator expanded operational capabilities, and use of pre-made/fabricated wires and equipment. These kits are:

- **MFJ-57B**, which contains a PVC Cross device for mounting a pre-cut and lugged wire loop to the top cover of the tuner. This flexible 10-gauge wire loop covers 20 and 30 meters, and the ends have low-resistance lugs.
- **MFJ-58B**, which contains all of the MFJ-57 items, plus a 40 meter, 15 - 20 meter and 10 - 17meter wire loops, with clips to hang loops as needed.

FAST-START INSTRUCTIONS

FAST START OPTION

Although careful and complete reading of the technical manual is certainly foremost when receiving new equipment, MFJ-936B *Loop Tuner*™ operation can be achieved with minimum time and effort as long as certain and specific instructions are followed. Strict adherence to **WARNINGS** and **CAUTIONS** associated with personal safety, coupled with following specific procedural steps can lead to a unique operating experience in a very short time.

WARNING

DO NOT touch or come into contact with *Loop Connectors* or *Loop Antenna* while transmitting

YOU CAN BE SERIOUSLY INJURED !!!

NOTICE

It is imperative that the operator specifically follows operating instructions and complies with all **CAUTIONS, WARNINGS, and FCC Guidelines for Human Exposure to Radiofrequency (RF) Electromagnetic Fields**

Step 1

Place the MFJ-936B *Loop Tuner*™ at the chosen place of operation, assemble the PVC Cross and connect the pre-cut loop antenna found in the MFJ-57B Accessory Kit to the wing nut terminals on the rear panel. Using the pre-cut loop antenna, form a loop around the PVC Cross to enclose as much area as possible. A circle encloses the maximum area.

Step 2

Complete the typical MFJ-936B *Loop Tuner*™ setup configuration as illustrated in Figure 6 of this manual.

FAST-START INSTRUCTIONS

Step 3

Pre-set the MFJ – 936B Loop Tuner controls to the following settings for the 14.2 MHz operation (settings are approximate, but should be reasonable):

- TUNING control to position “4 ½”.
- MATCHING control to position “9”.
- METER SENSITIVITY control to fully clockwise position.
- POWER RANGE switch position to “out, 30W range”

Step 4

Tune the transceiver or receiver to the 20 meter band and frequency of interest and “**Ear-ball**” fine-tune the MFJ-936B *Loop Tuner*™ controls for maximum noise and S-Meter reading. “Ear-balling,” like “Ball-parking” is a term often to describe the listening process as used to hear a “**peak**” in reception before actually applying a transmit signal to the tuner. The tuner will produce a peak when the exact position for the controls and switches is found.

Step 5

Apply 10 to 20 Watts of power to the MFJ – 936B Loop Tuner and adjust the TUNING control for maximum RF antenna current. Adjust the MATCHING control for minimum SWR on the MFJ - 936B SWR/Wattmeter. Re-adjust the TUNING control for maximum RF antenna current. Repeat this sequence until you see no further improvement in minimum SWR and maximum antenna current. Always adjust for maximum RF antenna current as the final adjustment. Be sure to adjust the RF Antenna Current Meter using the METER SENSITIVITY control for center scale reading as you make adjustments.

Step 6

Once you are satisfied that the adjustments and settings are correct for minimum SWR and maximum antenna current, you can advance the power to 150 Watts if desired. Be sure to set the POWER RANGE switch to “out” for the 300-Watt scale. Be sure that MPE distance standard is met. Should any arcing be detected, stop transmitting and check connections and proximity to objects that may be suspect. If arcing seems to be inside of the MFJ – 936B, Loop Tuner, lower output power and re-check for arcing.

FAST-START INSTRUCTIONS

As a courtesy to our fellow hams, for safety and to keep within FCC regulations you should use the minimum power needed for communications. 20 to 50 watts often provides very reliable communications. The difference between 50 and 100 watts is less than ½ S-unit and is not noticeable on the receiving end.

Step 7

You can now enjoy operating in your favorite mode. However, if you change frequency more than about 5 KHz, you may find you'll need to re-adjust the TUNING controls for minimum SWR. Rotate TUNING clockwise for higher frequencies and counter clockwise for lower frequencies. Even greater frequency excursions can cause the MATCHING control to also require adjustment.

This concludes the MFJ-936B Loop Tuner™ **Fast Start Operation** instructions.

TECHNICAL ASSISTANCE

TECHNICAL ASSISTANCE

If you have any problem with this unit first check the appropriate section of this manual. If the manual does not reference your problem or reading the manual does not solve your problem, you may call *MFJ Technical Service* at **662-323-0549** or the *MFJ Factory* at **662-323-5869**. You will be best helped if you have your unit, manual and all information on your station handy so you can answer any questions the technicians may ask.

You can also send questions by mail to MFJ Enterprises, Inc., 300 Industrial Park Road, Starkville, MS 39759; by Facsimile (FAX) to 662-323-6551; or by email to techinfo@mfjenterprises.com. Send a complete description of your problem, an explanation of exactly how you are using your unit, and a complete description of your station.

NOTES

Autoryzowany Przedstawiciel MFJ w Polsce:

abel & profit
centrum radiokomunikacji

INRADIO
ABEL & PRO-FIT Centrum Radiokomunikacji
ul. Puszkina 80 92-516 Łódź Poland
tel. (+42) 649 28 28 fax: (+42) 677 04 71
e-mail: biuro@inRADIO.pl
internet: www.inRADIO.pl