

MFJ

Tuner Kit

Model MFJ-941EK



INSTRUCTION MANUAL

CAUTION: Read All Instructions Before Operating Equipment

MFJ ENTERPRISES, INC.

300 Industrial Park Road
Starkville, MS 39759 USA
Tel: 662-323-5869 Fax: 662-323-6551

DISCLAIMER

Information in this manual is designed for **user purposes only** and is **not** intended to supersede information contained in customer regulations, technical manuals/documents, positional handbooks, or other official publications. The copy of this manual provided to the customer will **not** be updated to reflect current data.

Customers using this manual should report errors or omissions, recommendations for improvements, or other comments to MFJ Enterprises, 300 Industrial Park Road, Starkville, MS 39759. Phone: (662) 323-5869; FAX: (662) 323-6551. Business hours: M-F 8-4:30 CST.

INTRODUCTION

General Information:

This manual contains all the information you'll need to build, calibrate, and use your new MFJ-941EK Versa-Tuner II kit. The Versa-Tuner II is actually four very useful station accessories combined into one package. The first is MFJ's wide-range 300-Watt T-network that can match virtually any HF antenna you're likely to encounter. The second is our highly accurate dual-range SWR/Wattmeter that features cross-needle metering. The third is an eight-position RF-routing switch for selecting a variety of antennas, either through the tuner or around the tuner in bypass mode. And, finally, there's a built-in 300-Watt 4:1 balun to accommodate antennas using balanced feedline. Despite its versatility, the circuitry and mechanical layout for the MFJ-941EK are straight forward, and these instructions will guide you through assembly from start to finish.

Before You Start:

Prepare a clean work surface and use muffin tins, egg cartons, or small paper cups to organize your parts. To reduce eyestrain, choose an area with strong overhead lighting and add a high-intensity desk lamp for close-up work. Construction requires the tools listed below:

- [] Soldering iron with a narrow chisel tip.
- [] Soldering-iron holder with a moistened cleaning sponge.
- [] Your choice of leaded or lead-free solder with rosin or no-clean flux.
- [] Small needle-nose pliers or surgical hemostat.
- [] Side-cutter type wire nippers.
- [] Solder sucker or de-soldering braid
- [] Magnifying glass or loupe for reading component markings
- [] Phillips-head screwdriver
- [] 5/64" Allen wrench (for knobs)
- [] 3/32" Allen wrench (for shaft coupler)
- [] 1/4" nut driver (for 4-40 hardware)
- [] 5/16" nut driver (for 6-32 hardware)
- [] 3/8" nut driver (for 10-32 hardware)
- [] 7/16" nut driver (for insulated terminal posts)
- [] 1/2" nut driver (for 3/8" ID control-nuts)

As you work, watch for the four most common kit-building errors:

1. *Wrong Part:* Identify, sort, and organize all parts ahead of time.
2. *Reversed Polarity:* Double check diode and meter polarity.
3. *Defective Soldering:* Routinely check for cold solder joints or bridged tracks.
4. *Omitted part:* Check off each construction step as you go.

INTRODUCTION

Before soldering, always inspect leads and terminals for oxidation. If dull, clean or burnish them with a small brass-wire hobby brush or glass-fiber brush (available at Radio Shack). Clean surfaces and good heat distribution are the keys to strong solder.

MFJ-941EK Parts Inventory:

Use the bill of material (BOM) on the next page to account for all the pieces in your kit, checking each part off as you go. If there's a missing or damaged item, write down the MFJ part number and contact MFJ for replacement (see Warranty page for instructions). Most parts are packed in three plastic bags -- one for small hardware items, one for pc-board components and pre-cut wire, and a third for larger parts.



Figure 1.1: MFJ-941EK Tuner Kit

INVENTORY

Begin your inventory with the **hardware bag**. For identification purposes, PH = Phillips Head, SM = Sheet Metal Screw, SS = stainless steel, KEP = nut with an integral lock washer, OD = Outside Diameter, and ID = Inside Diameter.

<input checked="" type="checkbox"/>	Qty	Description	MFJ Part Number
<input type="checkbox"/>	8	4-40 x 3/8" Machine Screw, PH	654-0375
<input type="checkbox"/>	3	4-40 x 1/2" Machine Screw, PH SS	654-0500
<input type="checkbox"/>	3	4-40 x 1/4" Threaded Aluminum Spacer	716B-0250
<input type="checkbox"/>	11	4-40 Hex Nut, KEP	705-0440K
<input type="checkbox"/>	2	6-32 x 1/4" Machine Screw, PH	656-0250
<input type="checkbox"/>	1	6-32 x 1" Machine Screw, SS, PH	656-1000
<input type="checkbox"/>	1	6-32 Hex Nut, KEP	705-0632K
<input type="checkbox"/>	2	6-32 Hex Nut	705-0632
<input type="checkbox"/>	1	6-32 Flat Washer	710-0643S
<input type="checkbox"/>	2	6-32 x 1-1/4" OD Fiberglass Washer	714-06125
<input type="checkbox"/>	1	6-32 x 1/4" Nylon Spacer	718-1218-0250
<input type="checkbox"/>	8	#6 x 3/8" Screw, Sheet Metal, Black	656S-0375B-A
<input type="checkbox"/>	2	#6 x 3/8" Sheet Metal Screw	656S-0375A
<input type="checkbox"/>	2	10-32 x 3/32" Set Screw, Hex	660-0187-SA
<input type="checkbox"/>	1	10-32 x 3/4" Machine Screw, PH	660-0750
<input type="checkbox"/>	1	10-32 Hex Nut, KEP	705-1032K
<input type="checkbox"/>	1	10-32 Wing Nut	705-1032S-W
<input type="checkbox"/>	1	#10 Solder Lug	720E-0621L
<input type="checkbox"/>	1	#10 Split Lock Washer	711-1037S-SL
<input type="checkbox"/>	2	#10 Flat Washer	710-1050
<input type="checkbox"/>	1	1/4" ID Heyco Shaft Bushing	740-2102
<input type="checkbox"/>	1	1/4" ID x 1/2" OD x 3/4" Coupler, 10-32	725-3105
<input type="checkbox"/>	1	1/4" x 3-1/2" Metal Shaft, 1/2" Flatted End	725-2112
<input type="checkbox"/>	3	3/8" Hex Control Nut, Panel Mount	705-3732RI
<input type="checkbox"/>	3	3/8" ID x 5/8" OD Flat Washer, Metal	710-3762
<input type="checkbox"/>	1	3/8" ID x 5/8" OD Shoulder Washer, Fiber	714S-3762
<input type="checkbox"/>	2	3/8" ID x 5/8" OD Flat Washer, Fiber	714-3762
<input type="checkbox"/>	4	3/8" ID x 3/4" OD Flat Washer, Fiber	714-3775
<input type="checkbox"/>	1	3/8" ID x 5/8" OD Flat Washer, Teflon	714-3762T
<input type="checkbox"/>	4	3/8" ID x 3/4" OD Flat Washer, Teflon	714-3775T

INVENTORY

Next, inventory the **circuit board bag** containing small pc-board components and pre-cut wire. Color codes and number codes are included to help you sort resistors, capacitors, and chokes.

<input checked="" type="checkbox"/>	Qty	Description	MFJ Part Number
<input type="checkbox"/>	2	100Ω 1/4W Resistor (brown, black, brown)	100-2100
<input type="checkbox"/>	1	150Ω 1/2W Resistor (brown, green, brown)	101-2150
<input type="checkbox"/>	1	3.3k 1/4W Resistor (orange, orange, red)	100-3330
<input type="checkbox"/>	1	47K 1/4W Resistor (yellow, violet, orange)	100-4470
<input type="checkbox"/>	4	50-K Trimpot, 10-mm Horizontal Mtg	133-4500B
<input type="checkbox"/>	1	33pF Disc Ceramic Capacitor, 1kV (33)	200-0033-2
<input type="checkbox"/>	1	220pF Disc Ceramic Capacitor, 1kV (221)	200-0220-2
<input type="checkbox"/>	5	.01uF Disc Ceramic Capacitor, 50-V (103)	200-2100
<input type="checkbox"/>	1	3-10 pF Trim-Cap, Horizontal Mtg	280-2010
<input type="checkbox"/>	1	680 uH Choke (blue, gray, brown)	401-5680
<input type="checkbox"/>	1	Directional-Coupler Xfmr, .37-OD Toroid	10-01003
<input type="checkbox"/>	2	Schottky Diode, CDSH270 (or 1N270)	302-0270
<input type="checkbox"/>	1	Switch, DPDT, Push-On/Push-Off	504-0022
<input type="checkbox"/>	1	Switch, 4PDT, Push-On/Push-Off	504-0023
<input type="checkbox"/>	1	2.1-mm PCB Power Jack	601-6021
<input type="checkbox"/>	3	Hookup Wire, 5", Black	871-2400-0500
<input type="checkbox"/>	1	Hookup Wire, 5", Red	871-2422-0500
<input type="checkbox"/>	1	Hookup Wire, 5" Violet	871-2477-0500
<input type="checkbox"/>	1	Hookup Wire, 5" White	871-2499-0500
<input type="checkbox"/>	1	Tie Wrap, 4" Nylon	745-2149
<input type="checkbox"/>	8	Buss Wire, 5-1/4", #16 Tinned	870-0016-0525
<input type="checkbox"/>	1	Buss Wire, 6-1/2", #16 Tinned	870-0016-0650
<input type="checkbox"/>	1	#4 Shoulder Bushing, Teflon	740-1012T
<input type="checkbox"/>	1	Brass Eyelet (Small)	725-4108

INVENTORY

This list covers the **large item bag** of larger items:

<input checked="" type="checkbox"/>	Qty	Description	MFJ Part Number
<input type="checkbox"/>	1	PC Board, Single-Sided	861-0949E
<input type="checkbox"/>	3	Insulated Binding Post, Red, with Hardware	606-0003
<input type="checkbox"/>	4	SO-239 UHF Chassis Mount Connectors	610-2005
<input type="checkbox"/>	1	300-W 4:1 Balun on 1" Toroid Form	10-10002B
<input type="checkbox"/>	1	2-1/2" Precision Cross-Needle SWR Meter	400-3083A
<input type="checkbox"/>	1	Molded Plastic Meter-Mount Bracket	736-0201
<input type="checkbox"/>	2	12 - 313 pF Air-Variable Capacitor	282-2006
<input type="checkbox"/>	1	3/8" OD Plastic Pushbutton, Red	760-2140
<input type="checkbox"/>	1	3/8" OD Plastic Pushbutton, Black	760-2122
<input type="checkbox"/>	4	1/4" ID x 1" OD Knob, Black	760-0035
<input type="checkbox"/>	1	Switch, 8PDT, 2-Section Rotary	500-0028-1
<input type="checkbox"/>	1	2.1-mm DC Power Cable with Coax Plug	620-8321

Finally, these **separate bag** items are bagged separately.

<input checked="" type="checkbox"/>	Qty	Description	MFJ Part Number
<input type="checkbox"/>	1	941E Inductor and Switch Assembly	10-13003
<input type="checkbox"/>	1	MFJ-941E Aluminum Chassis	800-0941E
<input type="checkbox"/>	1	MFJ-941E Front Panel Decal (pre-installed)	782-0941E
<input type="checkbox"/>	4	Rubber Feet (pre-installed)	770-1162
<input type="checkbox"/>	1	MFJ-941E Chassis Cover, Black	804-0941E
<input type="checkbox"/>	1	Assembly and Operating Manual	925-0941EK

CONSTRUCTION

Key Assembly Instructions:

Key words are used to shorten the length of the assembly steps to one line. **Find** means to pull specific items from the parts inventory for installation. **Identify** means to look for a mark or feature that orients the part for installation. **Install** means to clean leads, insert them at a specified location, and bend or wrap them so the part stays in place. **Solder** means to apply solder, inspect the connection, and nip off protruding leads or pins. **Legend** refers to silk-screen lettering on the printed circuit board.

Circuit Board Assembly:

Find the circuit board and take a minute to survey the component-side legend for various part locations. When you're ready to begin construction, find the five resistors listed below:

- (2) 100 ohm (brown, black, brown)
- (1) 150 ohm (brown, green, brown)
- (1) 3.3K (orange, orange, red)
- (1) 47K (yellow, violet, orange)

- [] Install a 150 ohm 1/2-Watt resistor at **R1** and solder.
- [] Install a 3.3K resistor at **R2** and solder.
- [] Install a 100 ohm resistor at **R3** and solder.
- [] Install a 100 ohm resistor at **R4** and solder.
- [] Install a 47K resistor at **R9** and solder.

Next, find four (4) 50K trimpots (black, 3/8" OD, 3 pins)

- [] Install 50K at **R5** and solder.
- [] Install 50K at **R6** and solder.
- [] Install 50K at **R7** and solder.
- [] Install 50K at **R8** and solder.

Find the four (4) disc ceramic capacitors listed below. Note that three leftover .01 uF capacitors will be installed later.

- (1) 33pF (33)
- (1) 220pF (221)
- (2) .01 uF (103)

- [] Install 33 pF at **C3** and solder.

CONSTRUCTION

- Install 220 pF at **C5** and solder.
- Install .01 uF at **C6** and solder.
- Install .01 uF at **C7** and solder.

Find the 3-10 pF trimmer capacitor (white ceramic, ~1/2" OD, 3 pins).

- Install at **C4** and solder.

On the pc board, locate the legend marking for C12 (next to trimpot R5).

- Form a 1/4" jumper using a clipped-off lead end. Install at **C12** and solder.

Find the 680-uH RF choke (blue, gray, brown).

- Install 680-uH at **L2** and solder.

Find two (2) Schottky diodes, CDSH 270 (blue) and identify the banded end. Refer to Diagram 1.

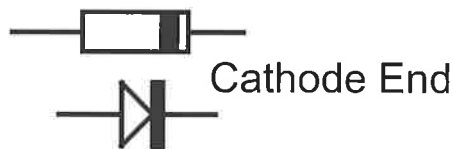

Diagram 1: Diode Orientation

- Install a diode at **D1** with the banded end (cathode) toward the D1 legend.
- Install the second diode at **D2** with banded end toward the D2 legend.

Find the following items:

- (1) Switch, DPDT, push-on/push-off (6 pins)
- (1) Switch, 4PDT, push-on/push-off (12 pins)
- (1) 2.1-mm PCB power jack

- Install the DPDT switch at **SW1**. Confirm all pins are fully seated, and solder.
- Install the 4PDT switch at **SW2**. Seat pins, and solder.
- Install the 2.1-mm power jack at **J1** and solder.

Find the 8PDT pc-mount 2-section rotary switch (from the larger parts bag)

- Orient the switch over the pc-board legend at **SW4** and install.
- Confirm all pins are firmly seated and solder.

CONSTRUCTION

Find the six (6) pre-stripped 5" lengths of jacketed hookup wire:

- (3) Black
- (1) Red
- (1) White
- (1) Violet

- [] Locate three holes marked **Ground** on the edge of the pc board near R8.
- [] Install a black wire in each and solder (free ends to be connected later).
- [] Install a red wire at **LMP** (behind SW1) and solder.
- [] Install a violet wire at **FMTR** (between SW1 and SW2) and solder.
- [] Install a white wire at **RMTR** (opposite side of SW2) and solder.

Find the following items to construct SWR transformer T2.

- (1) .37" OD toroid with bifilar winding
- (1) #4 Teflon shoulder bushing
- (1) Small brass eyelet
- (1) 5-1/4" length of #16 buss wire

Refer to Diagram 2 below:

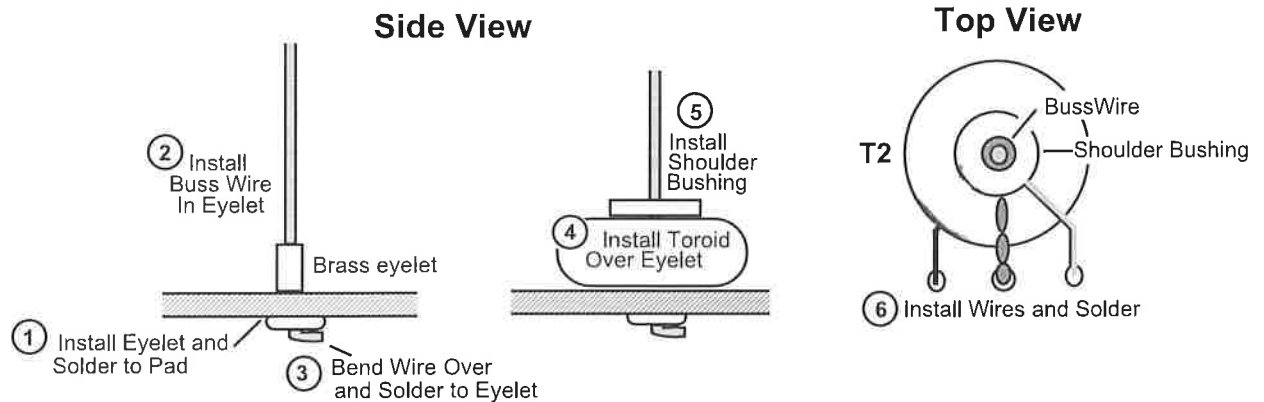

Diagram 2: SWR Transformer Installation

CONSTRUCTION

- [] Locate the pc legend for **T2**.
- [] On the solder side, install the brass eyelet through the T2 pad, as shown.
- [] Solder the eyelet flange in place, but do not fill the opening with solder.
- [] Insert buss wire into the opening and make a 90-degree bend at the end.
- [] Solder the bent end of the wire to the eyelet.
- [] On the component side, install the toroid over the protruding eyelet.
- [] Install the Teflon shoulder bushing on top, pressing it into the toroid center.
- [] Confirm toroid is flush with pc board and wires aligned with mounting holes.
- [] Install and solder all three leads (twisted tap lead goes in the center).

Find six (6) additional 5-1/4" lengths of #16 buss wire.

- [] Install a buss wire at **D/L** and solder (rear of SW4)
- [] Install a buss wire at **WIRE** and solder
- [] Install a buss wire at **COAX2** and solder.
- [] Install a buss wire at **COAX1** and solder.
- [] Install a buss wire at **C2** and solder (right front of SW4).

The sixth buss wire is connected between the pc board and a tab on SW4. Refer to Diagram 3 below:

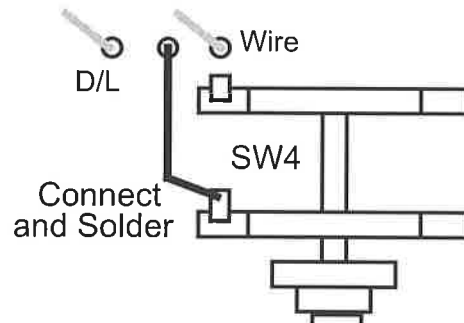

Diagram 3: SW4 Tab Location

- [] Install a buss wire at the unmarked hole between D/L and WIRE, and solder.
- [] Locate the exposed solder tab on top of SW4's *front wafer*.
- [] Route the buss wire to the designated terminal, install, and solder.

This completes circuit board sub-assembly. Note that several tuner models use the same pc board and some parts locations are not used for this project. Before moving on, take a few minutes to inspect and double-check your work.

CONSTRUCTION

PC Board Installation:

Find the MFJ-941E chassis. Also, find the following hardware items:

- (3) 4-40 x 1/2" Machine Screw
- (3) 4-40 x 1/4" Threaded Aluminum Spacer
- (3) 4-40 Hex Nut, KEP (nuts with lock washers)

Locate the three circuit board mounting holes on the bottom of the chassis. These form a triangle -- two at the rear and one in front. Spacers are mounted as shown below in Diagram 4:

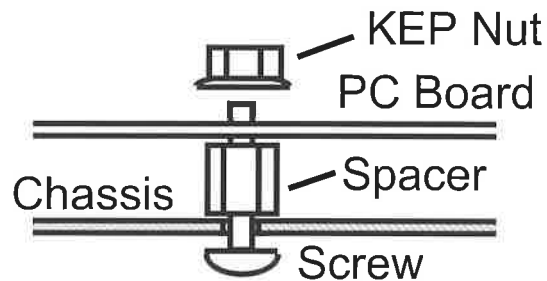

Diagram 4: PC Board Mounting

- [] Install spacers with 1/2" screws and spacer. Don't fully tighten.
- [] Align and install the circuit board on top of the spacers.
- [] Tighten the threaded spacers in place.
- [] Secure the circuit board on top of spacers using KEP nuts.

Rear Panel Components:

Coax connectors are mounted from the inside of the chassis as shown below in Diagram 5:

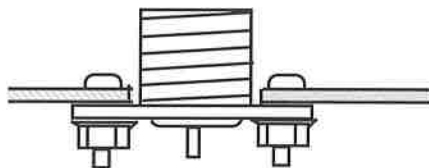

Diagram 5: Coax Mounting

CONSTRUCTION

Find the following coax connector items:

- (4) SO-239 female chassis-mount coaxial connector
- (8) 4-40 x 3/8" Machine Screw
- (8) 4-40 Hex Nut, KEP (nuts with lock washers)

- Install a connector at COAX 1 and tighten hardware.
- Install a connector at COAX 2 and tighten hardware.
- install a connector at TRANSMITTER and tighten hardware.
- Install a connector at DUMMY LOAD and tighten hardware.

On the pc board, locate the free end of each of the following wires and route them to the designated connectors.

- Route COAX1 buss wire to COAX 1 connector, trim, install, and solder.
- Route COAX2 buss wire to COAX 2 connector, trim, install, and solder.
- Route T2 buss wire to TRANSMITTER connector, trim, install, and solder.
- Route D/L buss wire to DUMMY LOAD connector, trim, install, and solder.

Find the following Ground Post items:

- (1) 10-32 x 3/4" Machine Screw, PHH
- (1) 10-32 Hex Nut, KEP
- (1) 10-32 Wing Nut
- (1) #10 Solder Lug
- (2) #10 Flat Washer
- (1) #10 Split Lock Washer

Locate the ground-post hole (GND) on the rear panel. Refer to Diagram 6.

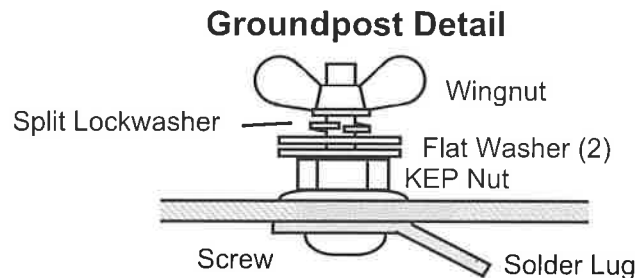

Diagram 6: Groundpost Mounting

- Install the solder lug on the screw and insert it out through back panel.
- Install the KEP nut and tighten in place securely.
- Install two flat washers

CONSTRUCTION

- [] Install the split lock washer.
- [] Install the wing nut (loosely).

From the larger parts bag, locate the three red plastic insulated terminal posts. Confirm that each one has a mating lock washer and nut. Install according to Diagram 7.

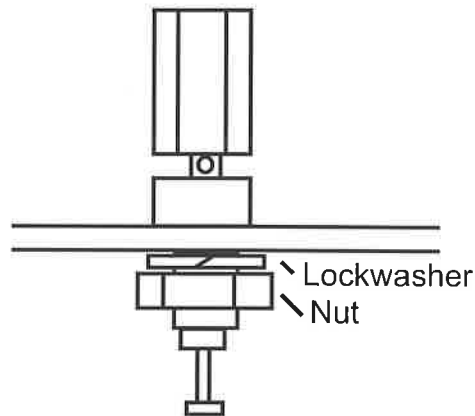

Diagram 7: Groundpost Mounting

- [] Install a terminal post at WIRE on the back panel (next to GND) and secure.
- [] Install two terminal posts at BALANCED LINE and secure.
- [] On the pc board, locate the buss lead labeled WIRE.
- [] Trim and install it on the WIRE terminal post. Solder.

Find the following components to install the 300-W 4:1 Balun:

- (1) 300-W, 4:1 Balun on 1" Toroid Form
- (1) 6-32 x 1" Machine Screw, SS, PH
- (1) 6-32 Hex Nut, KEP
- (1) 6-32 Flat Washer
- (2) 6-32 x 1-1/4" OD Fiberglass Washer
- (1) 6-32 x 1/4" Nylon Spacer

CONSTRUCTION

On the chassis, locate the balun transformer mounting hole (approximately 2" in front of the terminal posts and ground post). Refer to Diagram 8 below:

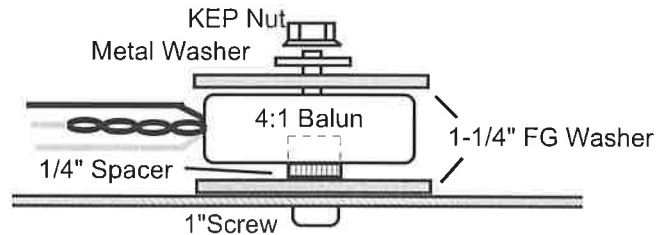

Diagram 8: Balun Mounting

- [] Insert the 1" machine screw up through the bottom of the chassis.
- [] Install a 1-1/4" fiberglass washer followed by the 1/4" nylon spacer on top.
- [] Install the balun over the spacer, orienting leads toward the back panel.
- [] Install the second 1-1/4" fiberglass washer to sandwich the balun in place.
- [] Install a #6 flat washer and KEP nut. Tighten, but don't crush balun windings.
- [] Locate B&W twisted lead on balun. Install on the ground-post lug and solder.
- [] Trim and install the white lead on either BALANCED LINE post and solder.
- [] Trim and install the black lead on the other BALANCED LINE post and solder.

Find the following items to prepare for installing the SWR meter:

- (1) 2-1/2" Precision Cross-Needle SWR Meter
- (1) Molded Plastic Meter-Mount Bracket
- (2) #6 x 3/8" Sheet Metal Screw
- (3) .01 uF Disc Ceramic Capacitors (marked 103)

CONSTRUCTION

Refer to Diagram 9 below during meter installation.

Locate the adhesive foam-tape pad adhered to the rear of the meter assembly. This pad is installed to cushion the meter bracket and provide tension. *Do not* remove the protective layer of tape to expose the adhesive underneath!

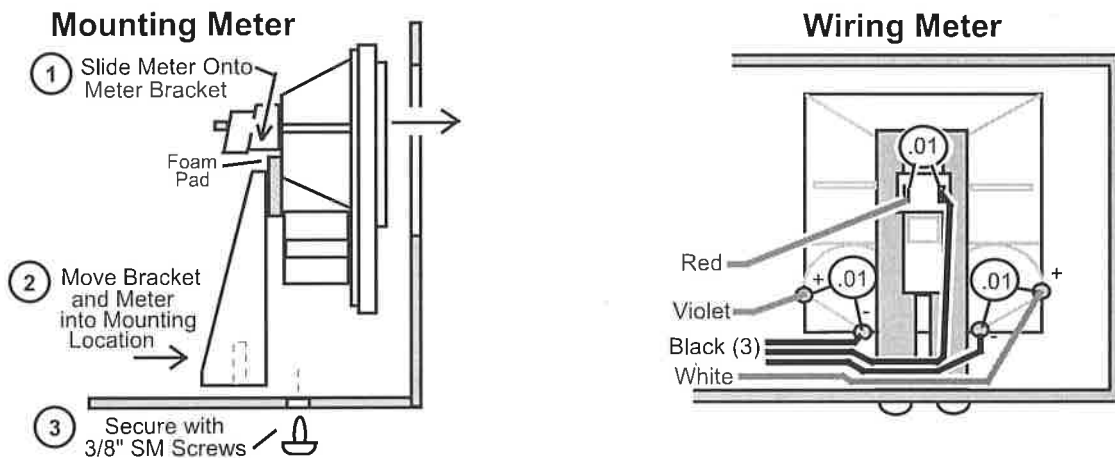

Diagram 9: Meter Mounting and Wiring

- [] Locate the lamp assembly that protrudes from the back of the meter.
- [] Orienting the bracket as shown, gently lower the meter onto it.
- [] Move into mounting position, aligning meter face with the panel opening.
- [] With bracket aligned on mounting holes, install using two #6-3/8" SM screws.

Refer to Diagram 9 wiring pictorial, install the .01 capacitors and hookup wire leads as shown:

- [] Install a .01 uF capacitor across the (+) and (-) terminals of each meter.
- [] Install a .01 uF capacitor across the terminals of the lamp assembly.
- [] Trim and install a black wire to the minus (-) terminal of each meter.
- [] Trim and install a black wire to either terminal of the meter lamp assembly.
- [] Trim and install the (FMTR) violet lead to the (+) terminal, side meter.
- [] Trim and install the (RMTR) white lead to the (+) terminal of the right meter.

CONSTRUCTION

Find the following parts for installation of the tapped tuning inductor:

- (1) Tapped Air-Wound Inductor and Switch Assembly
- (1) 3/8" Hex Control Nut, Panel Mount
- (1) 3/8" ID x 5/8" OD Flat Washer, Metal
- (1) 3/8" ID x 5/8" OD Shoulder Washer, Fiber
- (1) 3/8" ID x 5/8" OD Flat Washer, Fiber
- (2) 6-32 x 1/4" Machine Screw, PH
- (2) 6-32 Hex Nut

Look inside the air-wound inductor to locate two protruding solder lugs (see Diagram 10 below). These lugs will be used to attach the inductor to the chassis. Also, note that the frame of the wafer switch will be isolated from chassis ground using fiber washers. The shoulder washer centers the switch in the panel opening.

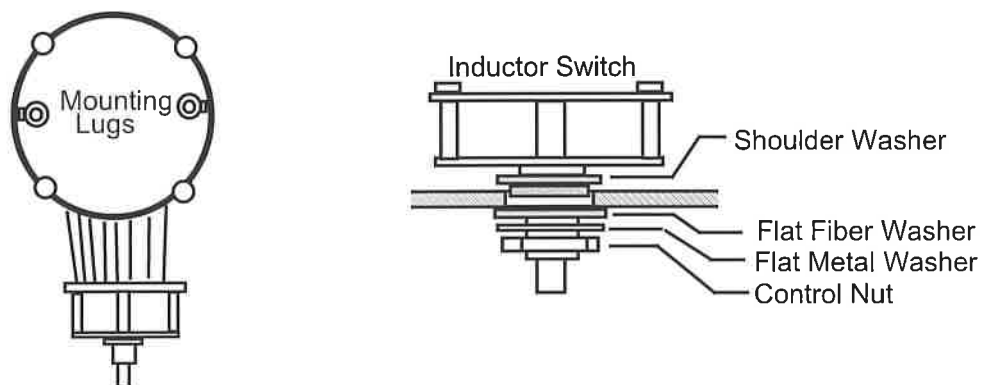

Diagram 10: Inductor Mounting

- [] Install the fiber shoulder washer on the Inductor switch, as shown above in Diagram 10.
- [] Insert the switch shaft at INDUCTOR and align coil lugs with chassis holes.
- [] Install two 1/4" screws up through the chassis and secure coil with hex nuts.
- [] Seat the switch and confirm that the shoulder washer is centered in the hole.
- [] Install a 5/8" fiber washer, metal washer, and control nut. Tighten in place

CONSTRUCTION

Like the Inductor switch, the Transmitter and Antenna tuning capacitors are isolated from the chassis by non-conductive washers. The Transmitter control uses fiber washers and the Antenna control uses Teflon washers. Find the following items:

- (2) 12-313 pF air-variable capacitors
- (2) 3/8" Hex Control Nut, Panel Mount
- (2) 3/8" ID x 5/8" OD Flat Washer, Metal
- (1) 3/8" ID x 5/8" OD Flat Washer, Fiber
- (2) 3/8" ID x 3/4" OD Flat Washer, Fiber
- (1) 3/8" ID x 5/8" OD Flat Washer, Teflon
- (2) 3/8" ID x 3/4" OD Flat Washer, Teflon

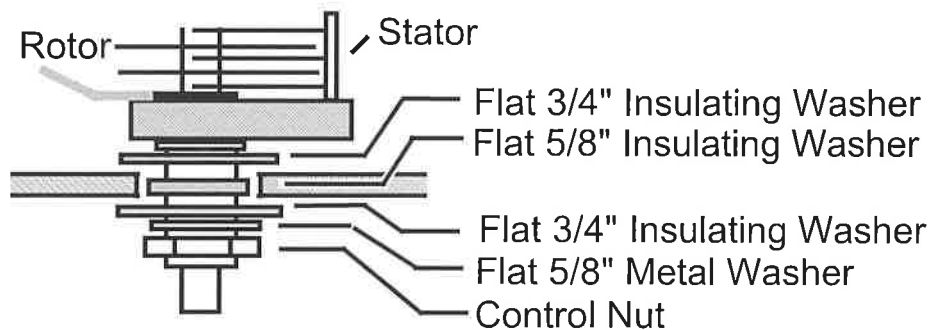

Diagram 11: Capacitor Mounting

- [] Install a 3/4" fiber flat washer on one of the variable capacitors.
- [] Insert the shaft at TRANSMITTER with the stator to the right side, as shown in Diagram 11.
- [] From the front, install a 5/8" fiber washer, centering it in the hole.
- [] Install a 3/4" fiber flat washer, a 5/8" metal washer, and a control nut. Secure.

Repeat the same procedure for the Antenna capacitor using the three Teflon flat washers.

- [] Install the other capacitor at ANTENNA, as shown.

CONSTRUCTION

Looking at the coil assembly, you'll see that the top winding has been cut and is isolated from the remainder of the coil. This wire is used to connect the stator of C1 to the pc board. It will be pulled back from the two front retainer rods and routed as shown below in Diagram 12:

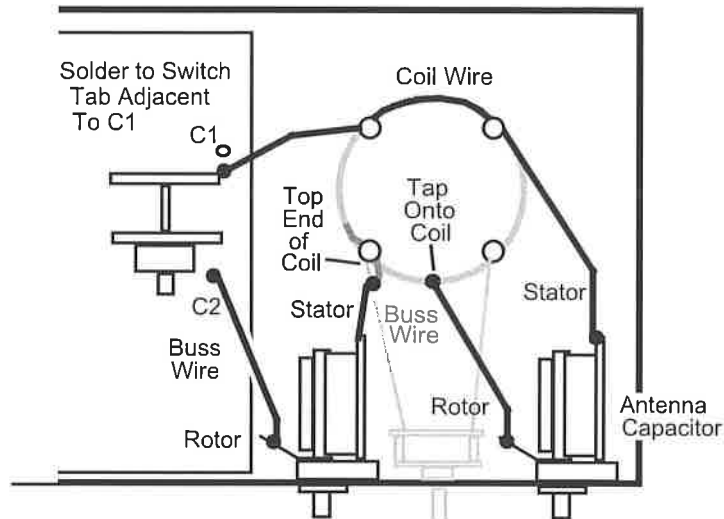

Diagram 12: Wiring Detail

- [] Carefully remove the top wire from the two front retainers, as shown.
- [] Trim and install the right lead end to the stator of the *Antenna* capacitor.
- [] Trim and solder the left lead-end to the switch tab adjacent to **C1** at SW4*

*The pad at legend **C1** and the exposed tab on SW4 are common to each other. Connecting the buss wire directly to the switch tab is simpler than lifting the board to solder it in at **C1**.

To complete tuner wiring, find the remaining #16 buss wire.

- [] Trim and install a buss wire onto the rotor tab of the *Antenna* capacitor.
- [] Install the opposite end as a tap on the exposed inductor winding, as shown.

Locate the left front retaining rod of the *Inductor*. There will be a curled-back wire-end at that location. That is the top end of the tuner coil.

- [] Install a length of buss wire onto the top winding of the coil (at left-front rod).
- [] Trim and install the opposite end to the *Transmitter* capacitor stator post.
- [] On the pc board, find the buss wire installed at **C2**.
- [] Install the opposite end to the *Transmitter* capacitor rotor tab (C2).

CONSTRUCTION

Tuner wiring is now complete. Before going on, check all solder connections and hardware for security. The next stage is final assembly.

Find the following items to complete the Antenna Selector Switch assembly:

- (1) 1/4" ID Heyco Nylon Shaft Bushing
- (1) 1/4" ID x 1/2" OD x 3/4" Shaft Coupler
- (1) 1/4" x 3-1/2" Metal Shaft with 1/2" Flatted End
- (2) 3/32" x 10-32 set screw, hex head
- (1) 1" OD Knob, Black with Silver Insert

Install the *Antenna Selector* shaft and knob as described below:

- [] Insert the Heyco nylon bushing into the front panel at *Antenna Selector*.
- [] Start two #10 Allen set screws into the shaft coupler (3/32" Allen Wrench).
- [] Install the shaft coupler on SW4. Secure rear set screw with a Allen wrench.
- [] Insert round end of shaft through the front panel bushing and into the coupler.
- [] Temporarily secure front set screw using an Allen wrench.
- [] Install the 1" knob, aligning its set screw with the flatted side of the shaft.
- [] Tighten the knob in place with a 5/64" Allen wrench.
- [] Rotate the switch fully counter-clockwise to its stop.
- [] Loosen front shaft-coupler screw, rotate knob to *Dummy Load* on the left side.
- [] Re-tighten the coupler set screw. Rotate knob and confirm pointer alignment.

Find these remaining items to complete final assembly:

- (3) 1" OD Knob, Black with Silver Insert
- (1) 3/8" OD Plastic Pushbutton, Red
- (1) 3/8" OD Plastic Pushbutton, Black

- [] Fully mesh *Transmitter* capacitor plates. Install knob with pointer at "0".
- [] Fully mesh *Antenna* capacitor plates. Install knob with pointer at "0".

To align the knob on the *Inductor* switch, first locate the switch's "home" or open position. Looking at the rear of the switch wafer, the wiper ring and selector tab should be aligned, as shown below. If not, temporarily install a knob and advance the switch until the two are aligned. See Diagram 13.

CONSTRUCTION

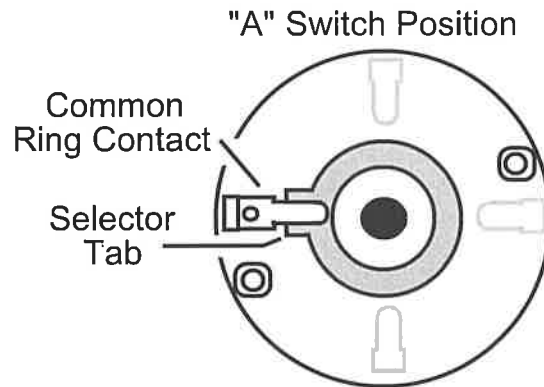

Diagram 13: Switch Alignment

- [] Align contacts and install a 1" knob at *Inductor* with the pointer at "A" .
- [] Install the red plastic pushbutton at *Lamp On-Off*.
- [] Install the black plastic pushbutton at *300W-30W* range switch.

The tuner's cover will be installed later, after testing and calibration.

TESTING

Test and Calibration:

These procedures require the following items:

- (1) 100-Watt HF transceiver with adjustable RF-power output
- (1) Accurate Wattmeter (Bird with 100H slug or calibrated digital meter)
- (1) Accurate 50-Ohm dummy load (100-Watt rating or higher)
- (1) Porcelain or plastic light socket with pigtail attached
- (1) 40-Watt incandescent "appliance" light bulb (do not use CFC bulb!)
- (1) Insulated straight-blade tuning tool for setting trimpots and trimcap
- (3) PL-259 patch cables, 3-feet or shorter.
- (1) Volt-Ohm test meter (VOM)

Pre-Test Inspection:

Perform these checks and correct any discrepancies.

- Check for loose hardware and tighten as needed.
- Inspect *Antenna* and *Transmitter* capacitor plates for rotor-to-stator shorts.
- With straightedge, confirm inductor is at 1/8" or more below top of panels.
- Inspect inductor. No taps, turns, or switch wires should be shorted together.
- Confirm meter needles both rest on zero.
- Confirm all knob pointers are aligned correctly and turn smoothly.
- Check pushbuttons to confirm push-on, push-off action without sticking.

Meter Lamp:

To test the meter lamp, use the 2.1-mm male power cable and a power source (12-volts DC or a 9-V battery).

- Connect voltage source to the power cable (either polarity okay).
- Plug 2.1mm cable into *Meter Lamp* on back panel and press *Lamp* switch on.

The meter lamp should illuminate

Antenna Selector Check:

Use the VOM set at Rx1. The first series checks the *Antenna Selector* in *Bypass* mode. Connect one lead to the center-conductor of the *Transmit* connector on the back panel. Rotate the *Antenna Selector* switch to each position below and check the corresponding coax connector for continuity:

TESTING

- [] Select *Bypass, Dummy Load*. Check *Dummy Load* connector.
- [] Select *Bypass, Bal Line Wire*. Check *Wire* binding post.
- [] Select *Bypass Coax-1*. Check *Coax-1* connector.
- [] Select *Bypass Coax-2*. Check *Coax-2* connector.

Now, check *Tune* mode for continuity. Move the common VOM lead from the *Transmitter* connector to the stator of the *Antenna* capacitor and repeat the test procedure.

- [] *Tuned, Dummy Load*
- [] *Tuned, Bal Line Wire*
- [] *Tuned, Coax-1*
- [] *Tuned, Coax-2*

4:1 Balun DC Check:

- [] Connect VOM leads across the *Balanced Line* terminals and confirm continuity.

Power Meter Calibration:

The accuracy of your MFJ-941E SWR/wattmeter depends on the reference standard you use for calibration. A Bird through-line wattmeter with a 100H slug (100-W) is probably the best choice. A high-quality digital meter with certified accuracy will also work well. Avoid using low-cost references with unknown specifications. Also, your 50-Ohm dummy load should be capable of handling 100W without overheating and changing value.

To avoid abrupt full-scale meter excursions, pre-set the meter calibration trimpots to the approximate settings shown below in Diagram 14:

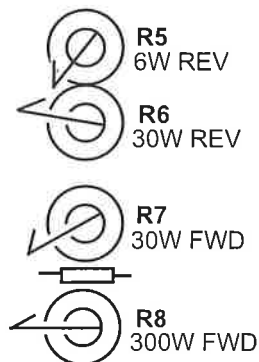

Diagram 14: Trimpot adjustments

TESTING

The calibration procedure is conducted on 20 Meters at 14.200 MHz. For radios equipped with analog RF-output controls, start each test run at minimum power and turn it up to the prescribed level while watching your reference power meter.

When the transmitter is activated, *high RF potentials will be present* on exposed tuner components. Inadvertent contact with energized surfaces can -- and will -- cause serious RF burns. Keep hands clear at all times and use an *insulated tuning wand* when adjusting trimmers.

Important Warning: Do not place hands on or near energized tuner components during testing. Always use an insulated tuning wand when making adjustments.

Finally, never actuate the *Inductor* or *Antenna Selector* switch when RF power is being applied. "Hot switching" the tuner circuitry will cause arcing and permanently damage tuner components.

Important Warning: Do not actuate the *Antenna Selector* or *Inductor* switch with RF applied. Damage to your tuner and radio may result!

Forward Power Setup and Bridge Null: To begin calibration, tune your radio to 14.200 MHz and select a mode that will deliver the radio's full rated CW output. Use short 50-Ohm coaxial patch cables (3 feet or less) for interconnections -- the shorter the better. The basic test configuration is shown below in Diagram 15:

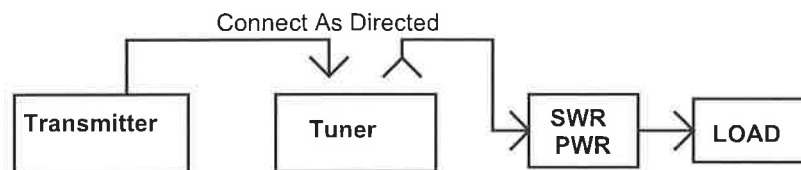

Diagram 15: Test Setup

- [] Connect the transceiver to the *Transmitter* connector.
- [] Connect *Coax-1* to the reference wattmeter's input jack.
- [] Connect the wattmeter's output jack to a 50-Ohm Load.
- [] Set the tuner *Antenna Selector* to *Bypass, Coax-1*.

Again, please keep hands clear of tuner components when testing!

- [] Set the tuner wattmeter power-range switch to *300W* (button in).
- [] View the *Forward* scale and apply 100W. Set R8 for a 100-W reading.
- [] View the *Reflected* scale and adjust trimcap C4 for a null (0-W) reading.
- [] View the *Forward* scale and recheck for 100W reading. Reset R8 as needed.

TESTING

- Reduce transmit power to 20W.
- Change the range switch to 30W (button out).
- View *Forward* scale and apply power. Set R7 for 20W (200 on 0-300 scale).

Reflected Power Setup:

This procedure uses the same setup, *except the Transmitter and Coax-1 connections are reversed* to measure reflected power. Note that applied power levels will be lower (20W and 5W).

- Connect radio to *Coax-1*.
- Connect wattmeter and load to *Transmitter*.
- Antenna Selector* remains set on *Bypass, Coax-1*.
- Reset the power-range switch for 300W (button in).
- View the tuner's *Reflected* scale. Apply 20W and set R6 for a 20-W reading.
- Reduce power output to 5 Watts. Change range switch to 30W (button out).
- View *Reflected Meter*, set R5 for 5-W* ("50" on the 0-60W scale).

*If your radio will turn down to a lower power level, use a 2W or 3W reference instead of 5W.

T-Network Check:

This procedure checks the RF path through the T-network to confirm the three main tuner components are connected properly and functional.

- Connect your transceiver back to *Transmitter*.
- Connect your dummy load and reference meter back to *Coax-1*.
- Return the range switch to 300W (button in)
- Change the tuner *Antenna Selector* to *Tuned, Coax-1*.
- Set the *Inductor* switch to "J"
- Set the *Transmitter* and *Antenna* controls to "0" (capacitors fully meshed).
- Starting low, gradually increase power to 100W.

Forward power should read close to 100W, SWR near "0". To further verify control functions, momentarily change the *Transmitter* and *Antenna* settings -- you should see significant changes in SWR. Moving the *Inductor* setting by one step in either direction should also increase SWR (do not switch it with RF power applied!!).

TESTING

Balanced Line Check:

This test confirms the 4:1 balun is working properly.

- [] Install a short jumper from *Wire* to the *Balanced Line* terminal post above it.
- [] Connect a 40-W incandescent bulb across the two *Balanced Line* terminals.
- [] Confirm the transceiver is connected to *Transmitter*.
- [] Confirm *Antenna Selector* is on *Tuned, Bal Line Wire*.
- [] Set *Inductor* to "J". Set *Transmitter* and *Antenna* to "0"
- [] Apply 25W. Adjust *Transmitter* and *Antenna* for minimum SWR.

The bulb should illuminate. Remember to remove the jumper when disconnecting the bulb.

Installing Cover:

If all of the above tests were completed successfully, install the chassis cover, as outlined below. If not, consult "In Case of Difficulty" for trouble-shooting guidance.

- [] Position the cover with the top screw holes toward the front of the chassis.
- [] Find eight (8) 3/8" x 6-32 black sheet metal screws and install.

In Case of Difficulty:

As noted in the introduction, the MFJ-941E is really four station accessories in one package. If difficulty arises during testing, the problem can likely be isolated to one of them.

1. Antenna Switching: Recheck buss-wire solder connections at the various destinations. Also, check the switching action of SW4 and confirm that the shaft coupler is tight. If loose, the selector knob will read incorrectly. If no obvious faults are located, it may be necessary to disconnect the shaft assembly for SW4, disconnect buss leads, and lift the pc board to recheck solder-side connections.

2. SWR/Power Meter: Recheck component placement on the pc board and confirm correct values are installed. Also, confirm diode polarity (cathode bands toward the D1 and D2 legend). Check meter-lead connections and polarity markings. If the meter lamp or the range pushbutton switches are not working properly, it may be necessary to disconnect the SW4 shaft assembly, disconnect buss leads, and lift the board to recheck solder-side connections.

TECHNICAL ASSISTANCE

3. T-Network Circuitry: Recheck all solder connections and confirm the *Inductor* knob is oriented properly on the switch. Also, look for signs of burned or damaged switch contacts. Finally, carefully inspect the two variable capacitors for uneven plate spacing or shorted plates.

4. Balun: Recheck solder connections. If okay, remove the balun from its mount and inspect windings for damage caused by over-tightened hardware.

If you are still unable to resolve the difficulty, refer to the Warranty page to review options for factory assistance.

TECHNICAL ASSISTANCE

If you have any problem with this unit first check the appropriate section of this manual. If the manual does not reference your problem or reading the manual does not solve your problem, you may call *MFJ Technical Service* at **662-323-0549** or the *MFJ Factory* at **662-323-5869**. You will be best helped if you have your unit, manual and all information on your station handy so you can answer any questions the technicians may ask.

You can also send questions by mail to MFJ Enterprises, Inc., 300 Industrial Park Road, Starkville, MS 39759; by Facsimile (FAX) to 662-323-6551; or by email to techinfo@mfjenterprises.com. Send a complete description of your problem, an explanation of exactly how you are using your unit, and a complete description of your station.

OPERATING INSTRUCTIONS

MFJ-941EK Operating Instructions**General Installation Suggestions:**

As its "manufacturer", you are now quite familiar with the MFJ-941EK, its four basic station-accessory functions, and the location of all the controls, jacks, and switches. Acquiring this kind of inside-out knowledge is one of the true benefits and satisfactions that come with building a kit! Now that the project is complete, here are some common *do's* and *don'ts* to guide you when installing it at your station:

- [] *Do* install it where you'll have convenient access to all front panel controls.
- [] *Don't* install it where you could be exposed to RF-energized open-wire lines.
- [] *Do* install it using a short 50-Ohm coax cable.
- [] *Don't* install a balun between the transceiver and the tuner.
- [] *Do* connect the tuner chassis *directly* to your station ground.
- [] *Don't* exceed 300 Watts in either the *Tuned* or *Bypass* mode.
- [] *Do* use the dummy load option if you use a radio with a tunable PA.*

Dummy Load Option:

Standard operating procedure for a radio with a tunable PA is to "tune up" into a 50-Ohm load *before* connecting it to the tuner. If you're running a rig with a tube PA, we recommend installing a 50-Ohm load such as the MFJ-260C permanently at *Ext. Dummy Load*. Then, use this setup procedure:

- [] Set the *Antenna Selector* to *Bypass, Dummy Load*.
- [] Tune your transceiver PA stage into the 50-Ohm Load.
- [] Switch to the desired antenna in *Tuned* mode.
- [] Match the selected antenna using the T-network controls.

Once your radio has been tuned to the dummy load, don't change PA settings while adjusting the tuner. Let the tuner do the work! If you use a solid state radio with fixed 50-Ohm output, the pre-tuning procedure is not needed (or possible).

1. Using the SWR/Wattmeter Function:

The SWR metering circuitry in your tuner is similar to MFJ's popular MFJ-860 stand-alone power meter. In fact, with the *Antenna Selector* in *Bypass* mode, it functions exactly the same. However, when switched into *Tuned* mode, it becomes an integral part of the tuner circuitry and is essential for adjusting the T-network properly.

OPERATING INSTRUCTIONS

To measure forward and reflected power:

- [] Select the desired forward power range (300W or 30W) and transmit a carrier.
- [] View the *Forward* scale to read incident power.
- [] View the *Reflected* scale to read reverse power.
- [] For SWR, find the red curve closest to where the two meter pointers intersect.

To obtain highly precise SWR readings, record Forward and Reflected power levels, then plug them into the formula:

$$SWR = \frac{1 + \sqrt{\frac{P_r}{P_f}}}{1 - \sqrt{\frac{P_r}{P_f}}}$$

P_r = Reflected Power
 P_f = Forward Power

2. Using the Antenna Selector Switch:

The tuner's built-in *Antenna Selector* performs two functions:

- [] Switches the T-network in and out of the tuner's RF path.
- [] Selects between two coax lines, a single-wire feed*, and a dummy load.

If your transceiver has a tunable PA, you'll want to use the *Dummy Load* port in conjunction with an external 50-Ohm load. However, for solid-state radios with fixed 50-Ohm output, you may elect to use *Dummy Load* for a third coaxial-fed antenna (the RF path is the same as for *Coax-1* and *Coax-2*).

To accommodate ladder line or open-wire feeders, the internal 4:1 balun can be energized at *Balanced Line* (see balun instruction).

3. Using the T-network Tuner:

The T-network is a highly flexible tool for matching a wide range of loads into 50 Ohms. Here is a control description and the preferred method for tuning them:

- [] The **Inductor** switch provides *maximum inductance* at setting *A* and *minimum inductance* at *L*. Typically, you'll need more inductance at low frequencies and

OPERATING INSTRUCTIONS

less inductance at high frequencies. Rotating the knob clockwise -- from *A* toward *L* -- progressively decreases inductance and increases the tuner's operating frequency.

[] The **Transmitter** and **Antenna** capacitors deliver *maximum capacitance* at "0" and *minimum capacitance* at "10". This labeling may sound reversed until you consider that more coupling is needed at lower frequencies and less is needed at higher frequencies. Typically, we associate higher frequencies with a clockwise turn of the knob (see below):

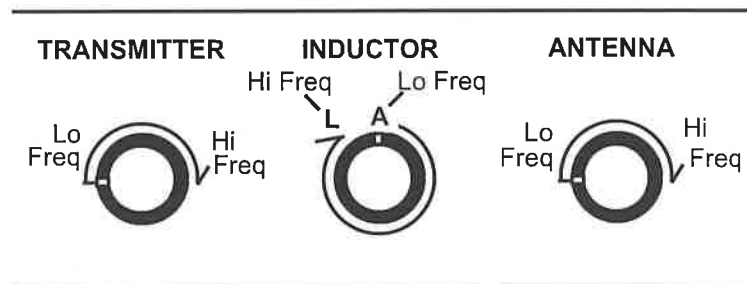

[] When tuning a T-network, start with a little more capacitance (tighter coupling) than you might actually need for your final match. Tighter coupling reduces the chance of arcing. Some users have suggested pre-setting capacitors fully meshed (0) for 160 and 75 meters, 3/4 meshed (2.5) for 60-20 meters, and 1/2 meshed (5.0) for 20-10 meters before starting to tune.

[] Once the capacitors are pre-set, find a starting point for the *Inductor* control by listening in receive mode and finding the switch position that yields the strongest background noise.

[] After the *Inductor* switch is set for highest background noise, apply a *low-power* carrier and alternately adjust *Transmitter* and *Antenna* for minimum SWR. If SWR won't approach 1:1, reset the *Inductor* switch by one step and try again. If the minimum SWR is higher still, go the opposite way. *Keep the power level low until SWR is nulled down to a relatively low level.*

[] Very often, there will be more than one inductor setting that will yield low SWR. With T networks, it's always advisable to *use the minimum amount of inductance and the maximum amount of capacitance* needed to obtain a good match. Loosely coupled higher-Q settings may yield acceptable SWR, but it increases the risk of arcing at high power. Think "C high, L low"!

OPERATING INSTRUCTIONS

[] Logging regularly used tuner settings is useful for two reasons. First, it speeds your setup time considerably. Second, it will alert you right away if something has changed out at the antenna site.

Note that T-networks are designed to match a wide range of loads, but they are *not designed to suppress your transmitter's harmonic content*. The T configuration is basically a high-pass filter, so it's up to your transmitter to do the filtering and meet FCC requirements for harmonic suppression.

4. Using the 4:1 Balun:

The 4:1 balun transforms loads connected at the *Balanced Line* terminal posts from Z_{in} to $Z_{out}/4$ and converts the signal path from balanced to unbalanced. Thus, a 200-Ohm load will be transformed to 50 Ohms (SWR = 1:1) and a 400-Ohm load will become 100 Ohms (SWR = 2:1).

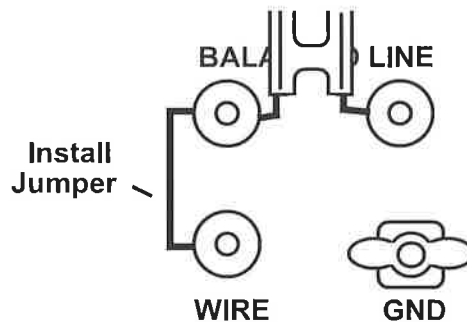

By switching in the T-network, it's possible to correct most (but not all) mismatches you might encounter. Some antenna and transmission line mismatches are so extreme that they defy correction. Low-impedance excursions are especially problematic for the tuner's balun because the 4:1 step-down transition will drive the impedance even lower -- sometimes beyond the range of the T-network! Fortunately, there are "fixes" for many of these problematic configurations.

OPERATING INSTRUCTIONS

Fixing Problem Antenna Systems:

The feedpoint impedance for most antennas you'll encounter will swing rapidly toward some high or low extreme as you move away from resonance. By the same token, depending on electrical length, the transmission line may take those extremes and transform them to some new extreme that is completely different! Fortunately, these problematic situations do occur with some predictability and a few simple changes can bring them under control. Without getting too technical, here are some time-tested tips for avoiding trouble in the back yard:

- [] Never center-feed a half-wave multi-band doublet with balanced line that is close to an odd multiple of an electrical quarter-wave.
- [] Never center-feed a full-wave doublet with a balanced line that is close to an even multiple of an electrical half-wave.
- [] If the tuner won't match a multi-band antenna on a particular band, change your feedline length by 1/8-wavelength (as calculated for the affected band).
- [] Never attempt to load a G5RV on a band below its half-wave design. Better to short the feed conductors together and load it as a monopole.
- [] Never attempt to load a 1/2 dipole on a lower-frequency than it was designed for. Again, better to short the feedline and load it as a monopole.

If you are having a problem with a particular dipole, here are some feedline lengths to try -- and some to avoid!

160-M Dipole: Try 35'-60', 170'-195', or 210'-235'. Avoid 130' or 260'

80-M Dipole: Try 34'-40', 90'-102', or 160'-172'. Avoid 66', 135' or 190'.

40-M Dipole: Try 42'-52', 73'-83', 112'-123', 145'-155'. Avoid 32', 64', 96', 128'

SCHEMATIC

MFJ-941EK Schematic Diagram:

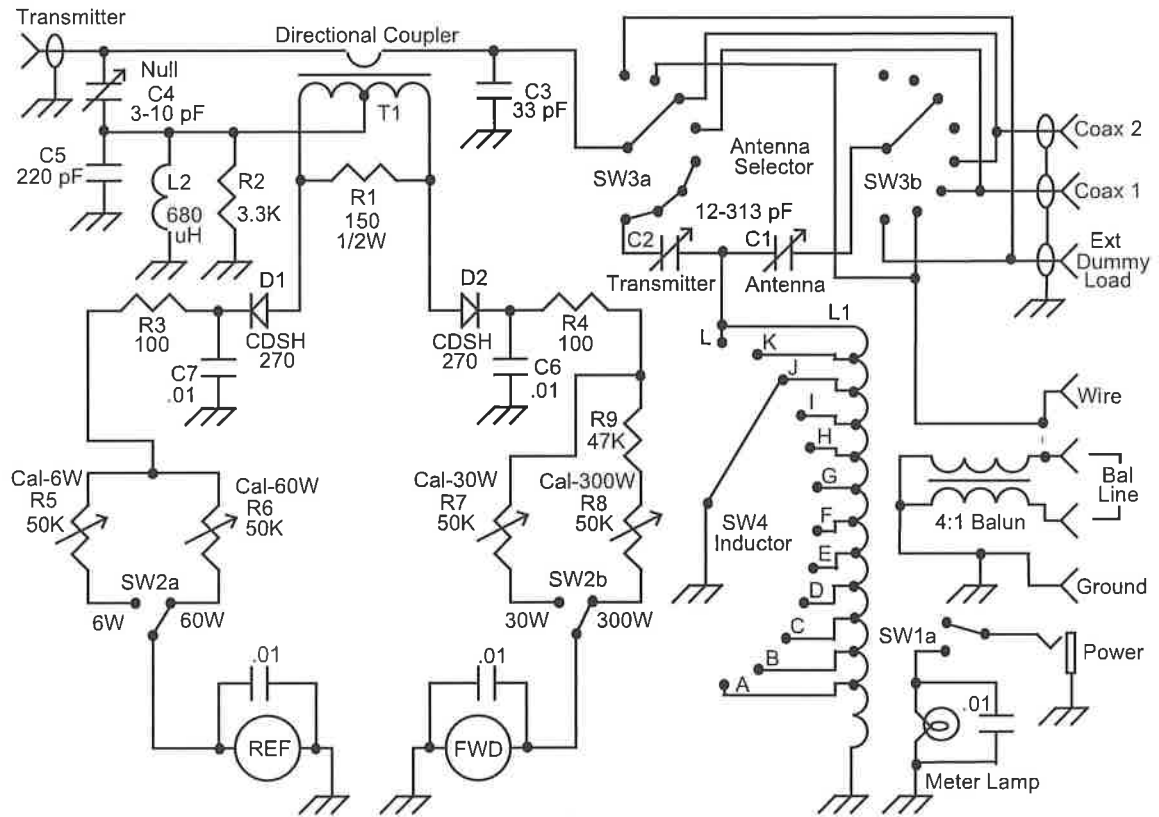

NOTES

IMPORTANT WARRANTY INFORMATION! PLEASE READ

Return Policy on Kits When Not Purchased Directly From MFJ Enterprises, Inc.: Before continuing any further with your MFJ kit check with your Dealer about their return policy. If your Dealer allows returns, your kit must be returned *before* you begin construction.

Return Policy on Kits When Purchased Directly From MFJ Enterprises, Inc.: Your MFJ kit may be returned to the factory *in its pre-assembled condition only*. The reason for this stipulation is, once you begin installing and soldering parts, you essentially take over the role of the device's manufacturer. From this point on, neither MFJ nor its dealers can reasonably be held accountable for the quality or the outcome of your work. Because of this, MFJ cannot accept return of any kit-in-progress or completed work as a warranty item for any reason whatsoever. If you are a new or inexperienced kit builder, we urge you to read the manual carefully and determine whether or not you're ready to take on the job. If you wish to change your mind and return your kit, you may—but you must do it *before* you begin construction, and within ten (10) working days of the time it arrives.

MFJ Enterprises, Inc. Warrants: Your kit contains each item specified in the parts list.

Missing Parts: If you determine, during your pre-construction inventory, that any part is missing, please contact MFJ and we'll send the missing item to you free of charge. However, *before* you contact MFJ, *please look carefully* to confirm you haven't misread the marking on one of the other items provided with the kit. Also, make certain an alternative part hasn't been substituted for the item you're missing. If a specific part is no longer available, or if Engineering has determined that an alternative component is more suitable, MFJ reserves the right to make substitutions at any time. In most cases, these changes will be clearly noted in an addendum to the manual.

Defective Parts: Today's electronic parts are physically and electrically resilient, and defective components are rare. However, if you discover an item during your pre-construction inventory that's obviously broken or unserviceable, we'll replace it. Just return the part to MFJ at the address below accompanied with an explanation. Upon receipt, we'll test it. If it's defective and appears unused, we'll ship you a new one right away at no charge.

Missing or Defective Parts After You Begin Assembly: Parts and materials lost or damaged *after construction begins* are not covered under the terms of this warranty. However, most parts supplied with MFJ kits are relatively inexpensive and MFJ can replace them for a reasonable charge. Simply contact the factory with a complete description. We'll process your order quickly and get you back on track.

Factory Repair After You Begin Assembly: *Kits-in progress and completed kits are specifically excluded from coverage by the MFJ warranty.* However, as a service to customers, technicians are available to evaluate and repair malfunctioning kits for a minimum service fee of \$18.00 (½ hour rate) plus \$7.00 shipping and handling (prices subject to change). To qualify for repair service, your kit must be fully completed, unmodified, and the printed circuit board assembled using rosin-core solder. In the event your repair will require more than an hour to fix (or \$36.00, subject to change), our technicians will contact you in advance by telephone before performing the work. Defective units should be shipped prepaid to:

MFJ Enterprises, Inc.
300 Industrial Park Road
Starkville, MS 39759

When shipping, pack your kit well and include the minimum payment plus shipping and handling charges (\$25.00 total). No work can be performed without pre-payment. Also, provide a valid UPS return address and a day time phone number where you may be reached.

MFJ-9416K



MFJ ENTERPRISES, INC.
300 Industrial Park Road
Starkville, MS 39759

MFJ-941EK Manual
Version 1A
Printed In U.S.A.