

MFJ

WARC Band Portable Antenna

Model MFJ-1795W



INSTRUCTION MANUAL

CAUTION: Read All Instructions Before Operating Equipment

MFJ ENTERPRISES, INC.

300 Industrial Park Road
Starkville, MS 39759 USA
Tel: 662-323-5869 Fax: 662-323-6551

MFJ-1795W WARC Band Vertical Antenna

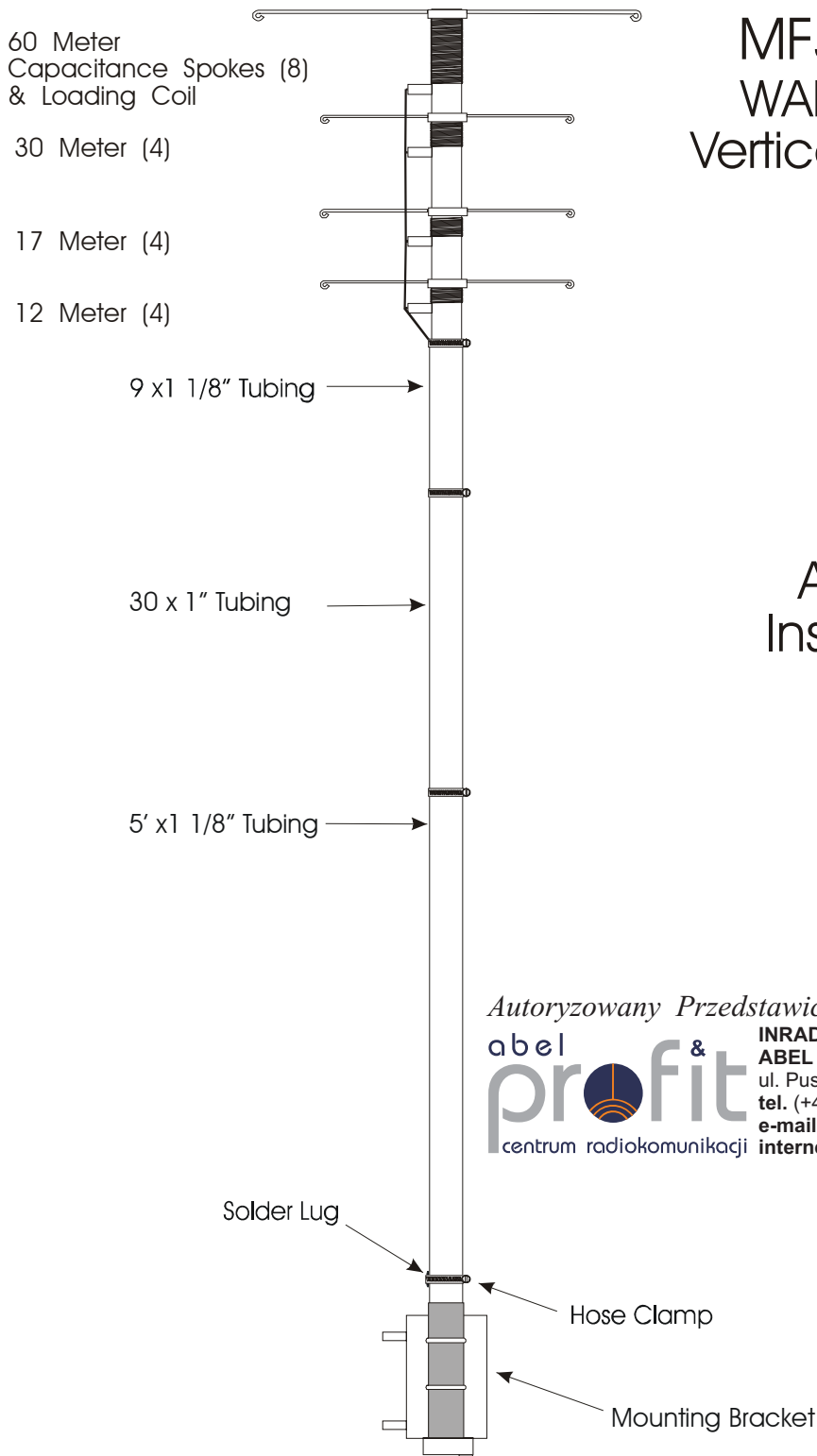

Always
Follow
Assembly
Instructions!!

Autoryzowany Przedstawiciel MFJ w Polsce:

abel & profit
centrum radiokomunikacji

**INRADIO
ABEL & PRO-FIT Centrum Radiokomunikacji**
ul. Puszkina 80 92-516 Łódź Poland
tel. (+42) 649 28 28 fax: (+42) 677 04 71
e-mail: biuro@inRADIO.pl
internet: www.inRADIO.pl

Note: This drawing is not to scale

WARC Bands Vertical Antenna

INTRODUCTION

The MFJ-1795W HF antenna was designed to provide portable or permanent WARC Band operation from restricted locations. When combined with the MFJ *Ground-Coupled™* Portable Antenna Base or other suitable grounding system, such as radial system, the result is a small vertical antenna under 10 feet in height.

The reduction in size is accomplished by adding separate loading coils and capacitance hats for each band at the top of the antenna. The efficient end loading coils are wound on fiberglass forms. The high quality materials and construction of the HF loading system allows a maximum power rating of 1500 watts SSB PEP on 60, 30, 17 and 12 meters.

The power rating of this antenna varies from band to band. The PEP ratings are primarily determined by the voltage breakdown of the components, while the CW ratings are generally determined by the components heating.

The following chart lists the power rating and the 2:1 VSWR bandwidth of this antenna:

<u>Band (Meters)</u>	<u>Power (Watts)</u>			<u>Bandwidth (KHz)</u>
	CW	SSB	RTTY	
60m	700	1500	500	100
30m	1250	1500	750	300
17m	1250	1500	1000	1000
12m	1250	1500	750	2000

The weight and wind load of this antenna are 10 pounds and approximately two square feet respectively.

WARNING: Improper installation and assembly can be hazardous! Read these instructions thoroughly before attempting to assemble, install, or operate this product! High power transmitting devices produce voltages that can cause severe burns or other injuries.

CHOOSING A LOCATION FOR THE ANTENNA

The best performance on receiving and transmitting will be obtained by mounting the antenna in a clear location above or away from buildings, towers, feed-lines, utility wires, and other antennas. While your own ingenuity and particular circumstances will determine the final mounting method, we will pass along a few ideas for both permanent and portable installation.

WARNING: Always mount this antenna so that it is out of the reach of adults as well as children. The capacitance elements can cause injury and or severe RF burns.

- **Never** place this antenna in a location that will permit people to encounter the loading spokes or any other part of the antenna.
- **Never** place this antenna where a mechanical failure might allow the antenna to contact power lines or other utility wires.
- **Always** ground the feed-line at the point where it enters a building to a good earth ground for lightning protection.
- **Follow** the guidelines for antenna installations as recommended by the US consumer product safety commission.

ANTENNA HEIGHT

The height of the radiating element is adjustable from 5 to 8 feet. Maximum radiation will be obtained by setting the height of the radiating element at 8 feet. Some installations may require the antenna height to be reduced. An example may be the installation of the antenna inside a backyard fence for concealment. Height adjustment will be discussed in the assembly section of this manual.

INSTALLATION

The MFJ-1795W was designed as a low profile, portable antenna. When combined with the MFJ *Ground-Coupled*TM Portable Antenna Base the antenna will provide permanent or portable communications. This is an ideal antenna for restricted locations. However, the antenna installation **MUST** be protected with non-metallic fencing to provide personal safety and to prevent antenna damage. The antenna can be installed using the supplied mounting bracket and a suitable ground radial system.

IMPORTANT: A suitable ground plane must be installed with this antenna.

PORTABLE SETUP

The antenna may be disassembled to the extent necessary for transporting to a temporary location. Before the antenna is disassembled, some type of marks should be placed on the mast of the antenna to ensure it will be the same height as before. *Some retuning may be required after moving the antenna.*

WARNING: If the antenna falls it will be damaged and may cause serious injury. Whatever type of installation you choose, remember that the antenna should be installed where it can *never* be contacted by people or animals.

TOOLS AND TIME REQUIRED FOR ASSEMBLY

The estimated assembly time for this antenna is 1 hour. Antenna assembly requires the following hand tools:

- soldering iron and solder
- 5/16" nut driver (or 1/4" flathead screwdriver)
- 7/16" open end wrench
- Heavy wire cutters for trimming capacitance spokes
- small pliers
- #1 phillips screwdriver
- #2 phillips screwdriver
- suitable eye protection

In addition, you will need two stable supports at least 30" tall (i.e. saw horses or trash cans) and a short (6 to 8 feet) temporary mast (1 to 1-1/2 inches outside diameter) for temporary mounting during tuning.

MFJ-1795W PARTS LIST

As you unpack your antenna you should find the parts in the following list.

- two (2) bundles of wire capacitance spokes eight (8) 21" spokes, and 14 36" spokes, and two (2) spare 21" spokes.
- 5' radiator 1 1/8"
- 30"x 1" radiator
- 9"x 1 1/8" radiator
- loading coil assembly
- base mounting bracket
- hollow fiberglass rod insulator
- One Hardware Bag containing**
 - 4 1.5" hose clamps
 - bag of short 6-32 stainless screws
 - bag of 6-32 stainless kep nuts
 - bag of 1/8" plastic spoke caps
 - 4 U-bolts with hardware
 - two plastic tie wraps
 - 2 solder lugs

For installation you will need some additional items not supplied with the antenna installation kit.

- Quality low-loss 50-Ohm coax with a PL-259 to go from the antenna to the transmitter.
- Either a SWR meter or Analyzer (MFJ-259B, 269)

SAFETY PRECAUTIONS:

WARNING: You can be killed if the antenna, feed-line, or the equipment used to install the antenna accidentally contacts any utility lines. Never install an antenna near power lines!

1. Be careful while carrying the antenna. It is heavy enough to cause you to lose your balance if it is handled too casually or if the capacitance spokes become entangled in obstructions.
2. Mount the antenna in a way so that it is out of reach. The ends of the capacitance spokes can cause eye injury, serious RF burns or both.
3. Make sure that a mast, if used, is sturdy enough to support the weight and the wind load.

ASSEMBLY AND INSTALLATION PROCEDURE

During assembly of this antenna refer to the figures in this manual and the picture on Page 1.

NOTE: Wear safety glasses whenever working on or near this antenna.

Do not tighten the screws that connect the loading coil terminal lugs to the capacitance hats or you will BREAK the fiberglass form. If the terminal lugs loosen tighten the NUT on the lug.

STEP-BY-STEP PROCEDURE

- [] 1. Prepare a temporary work surface, such as a table, two saw horses, or trash cans, to be used while installing the parts onto the antenna.
- [] 2. Sort out the parts you have unpacked into groups of similar parts. Be sure all the parts are available.
- [] 3. After examining the antenna parts, gather the tools needed for basic assembly. At the minimum these consist of:
 - [] #1 Long Phillips screwdriver for capacitance spoke screws
 - [] 1/4" flathead screwdriver or a 5/16" nut driver for hose clamps.
 - [] Two 7/16" open end wrenches or one wrench and one nut driver for the U-bolts.
 - [] Heavy Wire cutters for trimming capacitance spokes.
 - [] Safety glasses.
- [] 4. Decide on the approximate height of the antenna. Maximum height will be just under 10 feet while minimum will be 6 1/2 feet. The antenna will operate best at a height of 10 feet.
- [] 5. The 6 1/2 foot level can be reached by using the 5' radiator. If this is the desired height steps 6-8 may be skipped. Heights above this level will be reached using the additional pieces of tubing.

- [] 6. Now take the 1.0" x 30" piece of aluminum and place at a minimum 2 inches into the long aluminum element (5' x 1 1/8"). The end of the long (5') piece used should be the one without the hole drilled in it. See Figure 1.
- [] 7. A hose clamp should be placed around the 1 1/8" pipe to secure it in place. Tighten it with the 5/16" nut driver.
- [] 8. A minimum of 2 inches of the 9" x 1 1/8" pipe should be placed onto the 1.0" x 30" piece of aluminum and secured with a hose clamp.

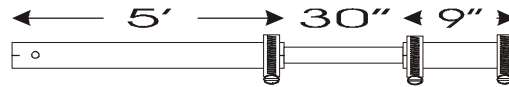

Figure 1

NOTE: The length of tubing placed inside 1 1/8" tubing will determine the overall height of the antenna.

- [] 9. Now the hollow fiberglass insulator should be placed approximately 3 1/2" into the 60" x 1 1/8" aluminum tubing. See Figure 2.

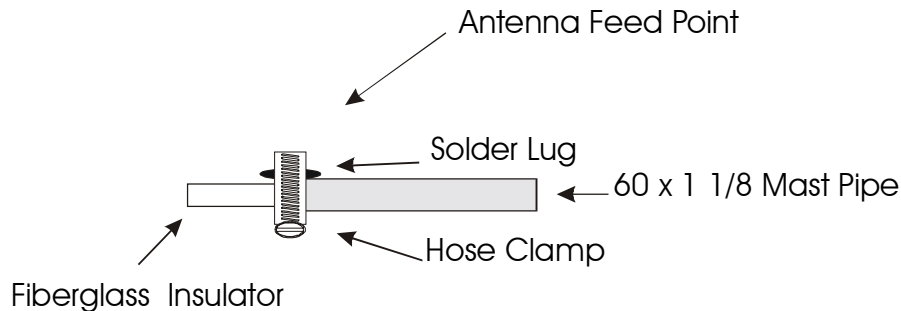

Figure 2

- [] 10. Place one of the hose clamps around the aluminum tubing and snug the clamp using a 5/16" nut driver . The center conductor of the coax will be connected to the antenna using a solder lug placed under the clamp. Refer to figure 2.
- [] 11. Place one of the small plastic spoke caps from the parts bag onto the end of each of the capacitance spokes.
- [] 12. Install the short 6/32" screws in the rings of the loading coil assemblies and place a 6/32" nut on each screw. Place eight (8) of the 36" capacitance spokes into the eight holes on the top rings of the loading coil assembly (60M). Then, tighten the screws until the spokes are snug. Now you should be able to turn the coil assembly over and they should balance on the long spokes. See Figure 3 and Figure 4.

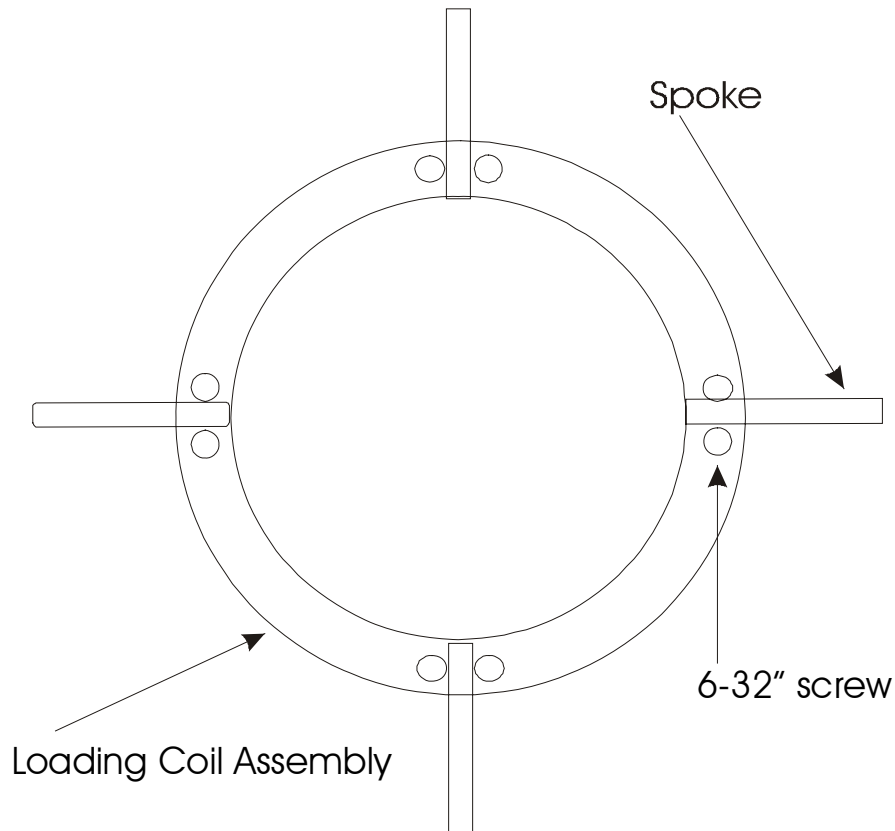

Figure 3

IMPORTANT: Do not use a high torque electric screwdriver to mount the capacitance spokes. The screw heads will be sheared off if too much torque is applied.

- [] **13.** Install four 36" capacitance spokes in the next sets of rings (30M). Again, tighten these spokes as was done in step 9. (See Figure 3 and Figure 4)
- [] **14.** Install four 21" capacitance spokes in the remaining two sets of rings (17/12M). Again, tighten these spokes as was done in step 9. (See Figure 3 and Figure 4)
- [] **15.** Slide a hose clamp over the top radiator. Mount the top coil assembly to the antenna by inserting the fiberglass insulator in the top radiator. Tighten the metal strap from the coil assembly under the hose clamp. See Figure 4.

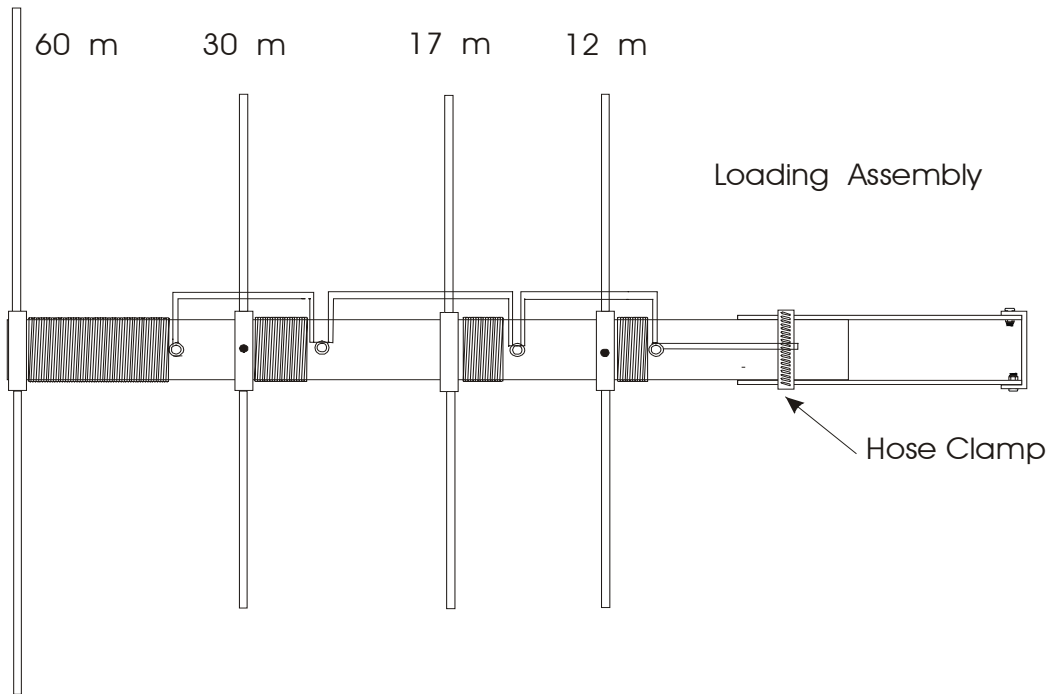

Figure 4

- [] 16. Double check the tightness of all the hardware you installed. Then, mount the antenna on the short temporary tuning mast or the MFJ Ground Coupled Portable Antenna Base.
- [] 17. Secure the mounting bracket to the fiberglass insulator as shown in Figure 5. Make sure the antenna mast does not contact the U-bolts. The next four steps may be skipped if the antenna uses the MFJ-1904 Antenna Base.

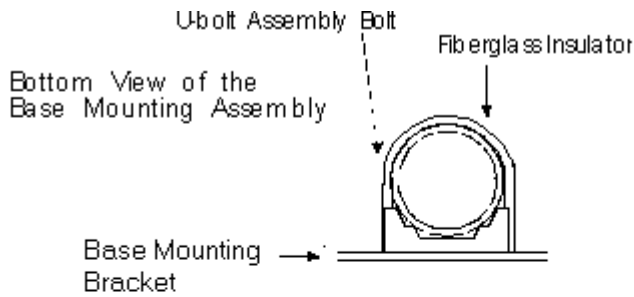

Figure 5

- [] 18. Ground radials should be attached to the U-bolts on the Base Mounting Bracket.
- [] 19. The antenna should be fed using a good quality 50-Ohm low-loss coax such as RG-8 or RG-58. Approximately 4 inches of the outer insulation should be removed. The center conductor of the coax should be soldered to the solder lug that was placed on the ¼" bolt in step 10 of the assembly. The outer shield of the coax should be soldered to the additional solder lug supplied in the parts bag. Place this solder lug onto one of the U-bolts located on the mounting bracket. Secure it using one of the ¼ "nuts supplied with the U-bolts.

WARNING: Serious burns can be received with improper use of a soldering iron.

- [] 20. Tune the antenna by following the instructions under the section "Frequency and SWR Adjustment".
- [] 21. Mount the antenna in its permanent location. Slight retuning and height adjustment may be necessary.

USING THE MFJ *GROUND-COUPLED*TM PORTABLE ANTENNA BASE WITH THE MFJ-1795W

The antenna base should be assembled using the instructions supplied with the unit. The following instructions will explain the installation of the MFJ-1795W to the antenna base.

- [] 1. The U-bolts should be attached to the base through the holes as indicated in Figure 5.
- [] 2. The SO-239 connector, supplied with the base, should then be installed on the top of the base plate mount as indicated in Figure 6 using two 6/32" x 3/8" screws and keps nuts supplied with the base. One of the feed-points at the bottom of the base may also be used. The insulated wire supplied with the MFJ-1904 will be long enough for this application. This will increase the radiating length of the antenna.

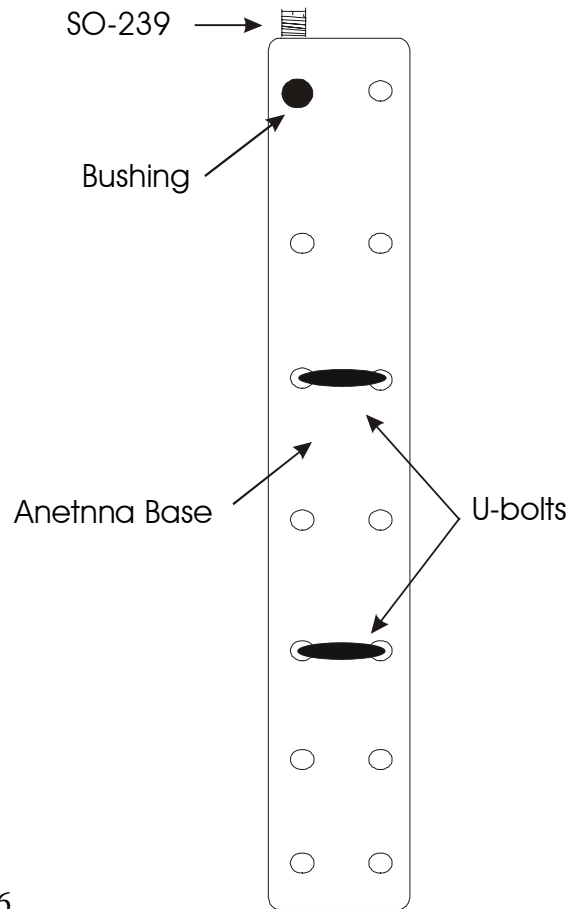

Figure 6

- [] 3. The plastic bushing supplied in the parts should be placed in the hole under the SO-239 connector.
- [] 4. Now the 15" piece of insulated wire should be passed through the plastic bushing to the antenna feed-point.

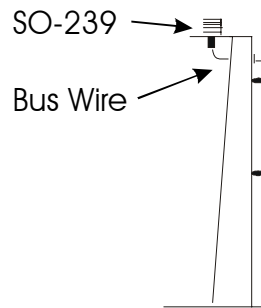

Figure 7

WARNING: Serious burns can be received with improper use of a soldering iron.

- [] 5. The wire should now be soldered to the center pin of the SO-239 connector.
- [] 6. Remove the fiberglass tubing from the aluminum tubing of the assembled antenna by loosening the hose clamp. Place the solder lug, under the hose clamp and retighten.
- [] 7. Insert the fiberglass tubing through the U-bolts and tighten the nuts. This will make base installation much easier.
- [] 8. Adjust the wire length so that it approaches the soldering lug at the antenna feed-point.
- [] 9. Carefully solder the insulated wire to the solder lug.
- [] 10. Tighten the nuts on the U-bolts firmly.
- [] 11. Re-attach the antenna to the fiberglass tubing by tightening the hose clamp. Remember to place the solder lug attached to the center conductor of the coax under the hose clamp
- [] 12. Make sure that the aluminum tubing, the insulated wire, and solder lugs **DO NOT COME INTO CONTACT WITH THE ANTENNA BASE**. Small readjustments of the fiberglass insulator may be necessary.

REMOVING THE ANTENNA FROM THE BASE OR BRACKET

The antenna may be quickly removed to be hidden from view. This is easily accomplished by loosening the hose clamp at the base of the antenna shown in Figure 2. Carefully pick up the antenna mast. Be sure to watch for overhead tree limbs and other objects that could come into contact with the antenna during removal. These objects could cause the antenna to become unbalanced and fall, resulting in personal injury and damage to the antenna. Store the antenna in a safe place to prevent damage.

FREQUENCY AND SWR ADJUSTMENT

This antenna covers wider frequency ranges on the higher bands, and narrower segments on the lower frequency bands. The 60-meter band has the narrowest range of operation (approximately 100 KHz) and is the most sensitive to adjustments.

The entire antenna must be accessible during initial tuning and testing. If the MFJ *Ground Coupled*TM Portable Antenna Base is used, attach the antenna to the base and place it in a location away from buildings or other objects that could affect the measurements. If the portable antenna base is not used, it is best to install the antenna on a short, temporary mast or pipe.

IMPORTANT: A suitable Ground radial system must be connected to the antenna mounting bracket if the Ground *Coupled Portable*TM Antenna Base is not used.

The SWR can be measured by using a transmitter and SWR bridge or an SWR Analyzer. The measuring device should be connected to the antenna with a reasonably short length of high quality 50-Ohm coaxial cable. If using a transceiver and SWR meter, set the transceiver to the lowest possible power to take measurements.

Please read the following hints:

- **The normal resonant frequency of this antenna is at or below the bottom of each amateur band.** This allows the user to "trim" a small amount off the *inside end* of the capacitance spokes to raise the resonant frequency. Conversely, adding a longer capacitance spoke will lower the resonant frequency of a loading assembly. Spare spokes are included in case you need to lower the resonant frequency of the antenna.
- **If the suspected resonant frequency is lower than your equipment can detect,** for example below 5.0 MHz, take one 60 meter spoke entirely off the antenna. Measure the resonant frequency again. If the resonant frequency still cannot be found, check another band. If none of these tests results in a good SWR on any frequency, substitute a 50-Ohm load for the antenna to test the feed line. If the SWR checks good, the antenna assembly will have to be checked for proper assembly, shorts, or openings at the feed point of the antenna.
- **If the antenna operates normally higher than the band after one spoke is removed,** install all the spokes and trim each spoke in 1/4 inch increments. The spokes for each band should be cut to the same length.
- **Once the resonant frequency is found,** use the chart located under the section Tuning The Antenna section of this manual to estimate the amount of the spoke length to cut so that the antenna will resonate at your favorite section of the band.

CAUTION: Always start tuning on 60 meters and adjust each band progressively higher in frequency. Adjustment of a lower frequency band will always have the most effect on the next higher frequency band. The tendency of the interaction is that if you move one band higher ALL the other bands move higher, but only very slightly. It is always best to "shoot for" the lowest end of the range you intend to use, and "trim in" by adjusting the bottom loading assembly after the antenna is in it's final location. ALWAYS work from the bottom band up.

Tuning the Antenna

1. Measure and record the frequency where the lowest SWR occurs on for each band. The lowest SWR should be at or below the bottom end of each HF band. The SWR should be below 2:1 at resonance on each band.
2. The following is a typical chart for initial measurements of a new antenna before tuning:

60 M 1.5:1 at 5.0 MHz
 30 M 1.3:1 at 9.7 MHz
 17 M 1.2:1 at 17.0 MHz
 12 M 1.1:1 at 23.6 MHz

If the resonant frequency is lower than what your equipment detected, take one spoke off to raise the resonant frequency. Measure the resonant frequency and calculate the approximate resonant frequency as if the spoke was in place using the chart on the below.

CAUTION: Be careful when working with the capacitance spokes. Contact with the sharp ends could result in injury or damage. When shortening the capacitance spokes be certain to replace the protective caps after each adjustment.

IMPORTANT: Due to the sensitivity of the resonant frequency on this antenna, small increments, such as 1/4 inch, should be considered when cutting the spokes to find the resonant frequency.

Begin tuning by trimming one 60-meter spoke by cutting off small, equal sections from the end of the spoke. Replace the small protective caps on the ends of the spokes each time you adjust the length. Continue adjusting until the antenna resonates approximately 15 KHz below the desired operating frequency. Use the chart below to *approximate* the amount of spoke to be trimmed. Trimming only one spoke from the top or bottom results in half the frequency change.

60 M: 1" trimmed off each of the spokes equals *approximately* 150 KHz

30 M: 1" trimmed off each of the spokes equals *approximately* 500 KHz

17 M: 1" trimmed off each of the spokes equals *approximately* 560 KHz

12 M: 1" trimmed off each of the spokes equals *approximately* 570 KHz

3. Now tune progressively higher frequency bands by trimming the spokes. Keep each set of capacitance spokes equal in size. **30 meters must be the second HF band adjusted, 17 the third and 12 meters last.** After adjusting 12 meters go back and check the other bands. Tighten all spoke screws.

GROUNDING CONSIDERATIONS

SAFETY GROUNDING MUST be provided to protect equipment, property, and persons from the hazards of lightning strikes and other weather related electrical discharges. In addition the coaxial cable feeding the antenna should have the shield grounded to eliminate the risk of any indoor equipment failure that would allow hazardous voltages to appear indoors creating a shock hazard.

Adequate protection can be accomplished by grounding the shield of the coax to a good earth ground where it enters the building to, or directly burying the cable in several feet of earth before it enters the building. The coaxial cable should be totally disconnected from the station during threatening weather conditions for MAXIMUM LIGHTENING PROTECTION.

MAINTENANCE

This antenna is constructed of heavy-duty non-corrosive materials and should withstand normal climates for many years. The use of some type of coaxial connector moisture protection is recommended at the bottom coax connection, especially in coastal areas where salty mist is commonplace.

TECHNICAL ASSISTANCE

If you have any problem with this unit first check the appropriate section of this manual. If the manual does not reference your problem or your problem is not solved by reading the manual, you may call *MFJ Technical Service* at **662-323-0549** or the *MFJ Factory* at **662-323-5869**. You will be best helped if you have your unit, manual and all information on your station handy so you can answer any questions the technicians may ask.

You can also send questions by mail to MFJ Enterprises, Inc., 300 Industrial Park Road, Starkville, MS 39759; by Facsimile to 662-323-6551; or by email to techinfo@mfjenterprises.com. Send a complete description of your problem, an explanation of exactly how you are using your unit, and a complete description of your station.

Autoryzowany Przedstawiciel MFJ w Polsce:

abel & profit
centrum radiokomunikacji

INRADIO
ABEL & PRO-FIT Centrum Radiokomunikacji
ul. Puskina 80 92-516 Łódź Poland
tel. (+42) 649 28 28 fax: (+42) 677 04 71
e-mail: biuro@inRADIO.pl
internet: www.inRADIO.pl